



MAHAGROUP

MPJ

Pit Jacks

Original Operating Instructions

BA550001-en

Installation | Operation | Service

MPJ 4.0/750 1S HM
MPJ 4.0/750 1S HA
MPJ 16.5/750 1S HM
MPJ 16.5/750 1S HA
MPJ 16.5/750 1S FA
MPJ 16.5/750 1S TA
MPJ 16.5/750 1S HAE

MPJ 20/750 1S HM
MPJ 20/750 1S HA
MPJ 20/750 1S FA
MPJ 20/750 1S TA

MPJ 16.5/1200 2S FA
MPJ 16.5/1200 2S TA
MPJ 16.5/1200 2S HA
MPJ 16.5/1200 3S FA
MPJ 16.5/1200 3S TA

© MAHA Maschinenbau Haldenwang GmbH & Co. KG

The reproduction, distribution and utilisation of this document as well as the communication of its contents to others without explicit authorisation is prohibited. Offenders will be held liable for the payment of damages. All rights reserved in the event of the grant of a patent, utility model or design.

The contents have been checked with great care; however, errors cannot be fully excluded. Illustrations are examples and may differ from the original product. Subject to technical change without notice.

Manufacturer

MAHA Maschinenbau Haldenwang GmbH & Co. KG
Hoyen 20
87490 Haldenwang
Germany

Phone: +49 8374 585-0
Fax: +49 8374 585-590
Mail: maha@maha.de
Web: www.maha.de

Service

MAHA SERVICE CENTER
Maybachstraße 8
87437 Kempten
Germany

Phone: +49 8374 585-100
Fax: +49 8374 585-491
Mail: service@maha.de
Web: www.mahaservicecenter.de

Dear Customer,

MAHA is one of the world's leading manufacturers of testing and lifting technology and places particular emphasis on quality and performance. The company's concept includes the development, manufacture and sale of products for use in automotive workshops, by vehicle manufacturers and testing organisations.

MAHA's claim is to also be a leader in the areas of reliability, safety and sustainability – this can be seen in many details that have been developed with these aspects in mind.

We are convinced that you will be more than satisfied with the quality and performance of our products for many years. With the purchase of our products you will also receive professional assistance in case of need for service and repair.

Please remember to keep these operating instructions in a safe place. Accurately following their contents will significantly extend the life of your product and also increase its resale value. If you sell your product, please also pass on the operating instructions.

MAHA is constantly working on the further development of all products and therefore reserves the right to make changes, e.g. in shape and appearance, without prior notice.

Extensive accessories, useful assembly material and auxiliary materials are available for our products. For further information, please ask your dealer or your MAHA contact person at any time.

Thank you for choosing a MAHA product!

Contents

1	General safety instructions	7
1.1	Symbols and signal words	7
1.1.1	Personal injury	7
1.1.2	Damages to products, machinery and equipment	7
1.2	Basic general safety instructions	7
1.3	Safety regulations for handling hydraulic oil.....	8
1.4	Procedure in the event of a malfunction	8
1.5	Procedure in the event of an accident.....	8
1.6	Requirements for the operating personnel	8
1.7	Requirements for service personnel.....	9
2	Intended and improper use	9
3	Service life	10
4	Machine description	10
5	Safety devices	12
5.1	Pressure relief valve	12
5.2	Self-closing drain valve	12
5.3	Overflow device for limiting the end position of the cylinders.....	12
5.4	HAE main switch.....	12
6	Technical data.....	13
6.1	Relevant pit dimensions	13
6.2	Nomenclature	14
6.3	Pit jack.....	15
6.4	Chassis.....	15
6.4.1	Suspended chassis	16
6.4.2	Rail-guided chassis	17
6.4.3	Freely movable chassis	18
6.5	Permitted pit jack-chassis combination.....	19
6.6	Danger zone	20
7	Transport, handling and storage	21
7.1	Safety instructions.....	21
7.2	Scope of delivery	21
7.3	Packaging information	22
7.4	Transport and handling	22
7.5	Storage	22
8	Installation.....	23
8.1	Safety instructions.....	23
8.2	Assembly of the rail-guided chassis.....	24
8.3	Mounting pit jack in suspended chassis	26
8.3.1	Adjustable chassis up to 16.5 t.....	26
8.3.2	Customized chassis 20 t	30
8.3.3	Customized chassis up to 16.5 t for telescopic pit jacks.....	31
8.4	Floor-running chassis	33
9	Optional equipment	34

9.1	Optional load handling attachments	34
9.2	Maintenance unit	34
9.3	Special accessories Bleeding	36
9.4	Foot pump	36
10	Operation	37
10.1	Control elements	37
10.1.1	MPJ 1S.....	37
10.1.2	MPJ 2S MPJ 3S.....	38
10.1.3	MPJ HAE.....	40
10.2	General safety instructions for safe operation	41
10.3	Positioning	42
10.4	Switch on.....	42
10.5	Lift.....	43
10.5.1	MPJ 1S.....	44
10.5.2	MPJ 2S MPJ 3S.....	44
10.5.3	MPJ HAE.....	45
10.6	Support	45
10.7	Lowering.....	46
10.7.1	MPJ 1S.....	46
10.7.2	MPJ 2S MPJ 3S.....	46
10.7.3	MPJ HAE.....	47
10.8	Moving units onto pit jacks	47
10.9	Extend.....	48
11	Troubleshooting.....	49
11.1	Manual/pneumatic-hydraulic pit jacks	50
11.2	Electrohydraulic pit jacks	52
12	Regular and recurring inspections	54
12.1	Daily before operating	54
12.1.1	Electrical connections (HAE).....	54
12.1.2	DL - Hoses.....	54
12.1.3	Leakage.....	54
12.1.4	Function drain/locking screw	54
12.2	Weekly	55
12.2.1	Piston rod	55
12.2.2	Pivot of the load suspension	55
12.3	Every 6 months	55
12.3.1	Oil level check.....	55
12.3.2	Rollers	55
12.3.3	Movement parts	56
12.3.4	Lifting brake.....	56
12.3.5	Pre-filter	57
12.4	Yearly inspection	57
12.4.1	Screw connections.....	57
12.4.2	Rollers on pit jack and FG	57
13	Servicing	58

13.1	Safety regulations	58
13.2	Washing / cleaning / oiling	58
13.3	Empty stroke	58
13.4	Maintenance unit	58
13.5	Lubricate	59
13.6	Change hydraulic oil	59
13.6.1	MPJ 1S.....	59
13.6.2	MPJ 2S MPJ 3S.....	63
13.6.3	MPJ HAE.....	68
13.7	Setting the pit jack brake.....	71
14	Repairs.....	72
14.1	Seal kit replacement MPJ 1S.....	72
14.2	Seal kit replacement MPJ 2S 3S.....	79
14.2.1	Tools required	79
14.2.2	Overview of components for seal kit	80
14.2.3	Work sequence for changing seal kit, 2S 3S pit jacks.....	80
14.3	Replace hydraulic unit	89
14.3.1	Replace hydraulic unit MPJ 1S.....	89
14.3.2	Replace hydraulic unit MPJ 2S 3S.....	90
15	Annex.....	91
15.1	Tightening torques.....	91
15.2	Load application of the chassis.....	91
15.3	Hydraulic oil filling quantities.....	92
15.4	Dimensions adjustable chassis	93
15.5	Overview of chassis rollers	94
15.6	Electrical circuit diagram MPJ HAE.....	96
15.7	Fluid plans	96
15.8	Operating instructions Maintenance unit.....	96
15.9	CE declarations of conformity	96

[Blank page]

1 General safety instructions

1.1 Symbols and signal words

1.1.1 Personal injury



DANGER

indicates an imminent danger. Death or severe injuries will follow if this danger is not avoided.



WARNING

indicates a potentially imminent danger. Death or severe injuries may follow if this danger is not avoided.



CAUTION

indicates a potentially imminent danger. Slight or minor injuries may follow if this danger is not avoided.

1.1.2 Damages to products, machinery and equipment

NOTICE

indicates a potentially harmful situation. The product or something in its vicinity may suffer damage if this is not avoided.

1.2 Basic general safety instructions

The following is a list of generally applicable safety instructions that must be observed for all work on and with the system. Safety instructions for special work are given at the beginning of the relevant chapter.

- This operating manual must be read carefully and understood before work commences.
- Please observe the specific safety information provided for the respective sections of the operating manual.
- Adhering to the procedures, sequences and corresponding safety instructions is essential.
- A printed copy of the operating manual must always be kept by the lift.
- The relevant regulations on accident prevention and health protection, in particular the use of personal protective equipment, must be observed.
- Electrical work may only be carried out by qualified electricians
- No persons may be in the danger zone during the lifting or lowering process

- When using optional load handling attachments, the relevant operating instructions must be observed in addition to these instructions.

1.3 Safety regulations for handling hydraulic oil

- Wear safety goggles and protective gloves when handling hydraulic oil
- Do not eat or smoke while working with hydraulic oil
- Neutralize spilled hydraulic oil with a binding agent.
- Immediately absorb any dripping with an absorbent cloth
- Remove soiled, soaked clothing immediately.
- After inhalation: Seek medical treatment in case of complaints.
- After skin contact: Wash skin immediately with soap and water. If skin irritation persists, consult a doctor.
- After eye contact: Rinse thoroughly with plenty of water, consult a doctor.
- After ingestion: Do not induce vomiting. Consult a doctor immediately.

1.4 Procedure in the event of a malfunction

- In the event of irregularities during operation, lower the lift immediately to the home position or support it.
- Turn off the main switch and secure against unauthorised use.
- MAHA Service Center by phone +49 8374 585-100 or via your contact person.

1.5 Procedure in the event of an accident

- Notify first aiders, the ambulance service and/or immediate care doctor:
 - Where did the accident happen (address, workshop ...)?
 - What happened?
 - How many are injured?
 - What injuries have occurred?
 - Who is reporting the accident?
- Keep calm and answer questions.

1.6 Requirements for the operating personnel

All persons involved in the operation of the system must:

- be 18 years of age or older,
- have the mental and physical capacity for their role,
- have been demonstrably trained and instructed in writing in the operation of the system,
- have read and understood the operating manual, and in particular the instructions on the procedure in the event of a malfunction,

- show knowledge and experience in handling the equipment and the dangers posed.
- be instructed on record in security guidelines.

1.7 Requirements for service personnel

Persons entrusted with the installation, maintenance and/or dismantling of the system must also:

- be demonstrably trained and instructed in the required work,
- be able to provide evidence of appropriate qualifications for work on the electrical equipment of the system (e.g. as a qualified electrician),
- Be able to provide proof of expertise for vehicle lifts. This includes sufficient knowledge in the field of lifts and the relevant national occupational safety regulations, accident prevention regulations and generally recognized rules of technology to be able to assess the safe working condition of the lift to be tested.

Competent persons must not only consider the current condition of the lift during the inspection. You must also be able to estimate how the lift and its structural parts will behave under operational conditions and how wear, ageing and the like will affect the safety of the lift.

2 Intended and improper use

- Observe the maximum axle load according to the load capacity specification on the rating plate of the jack and the load handling attachment!
- The pit jack is designed for use in vehicle workshops for the inspection, maintenance and repair of cars, trucks, buses, trailers and agricultural machinery and for lifting units.
- The jack is intended exclusively for lifting and lowering cars and commercial vehicles axle by axle for service and repair work.
- Use is only permitted with the load handling attachment suitable for the load.
- load handling attachment must be suitable for the load and its pick-up points in terms of load-bearing capacity, shape and position.
- Use is only permitted on a level, load-bearing surface (floor, pit, rail, etc.) that is suitable for the load.
- The maximum permissible inclination in all directions of the rail or floor is 1°.
- Lifted loads must always be safely supported in a suitable manner. Pit jacks and gearbox jacks are lifting devices and are not suitable for holding the load securely over a longer period of time
- The pit jack may not be modified without the express written permission of the manufacturer.



WARNING

Any use beyond the intended use is contrary to the intended use, e.g. it is prohibited,

- use the jack to support lifted loads
 - lift more than one axle at the same time
 - to step onto or ride on the load handling attachment
 - use the jack for other lifting work
 - use additional lifting gear for lifting
 - use the pit jack in potentially explosive atmospheres or outdoors
-

3 Service life

The product is designed as standard for 22,000 load cycles in accordance with EN 1493. The duration of the intended use in relation to the possible product service life must be assessed and determined by an expert during the annual equipment inspection.

4 Machine description

The pit jacks described here are not used on their own, but always in combination with corresponding chassis.

DIN EN 1494 distinguishes between pit jacks that can be moved in working pits on rails or on the pit floor and may only be moved without a load, and geared jacks that can also be moved when loaded and whose direction of travel is not restricted.

The pit jacks can be combined with different chassis within the limits of a sensible workflow and what is technically feasible.

There are basically three types of chassis. In addition to three types each of suspended and rail-guided chassis, the freely movable chassis is available for moving on the hall floor when used as a gearbox lift.

Suspended and rail-guided chassis can be moved along the guides - rails on the pit floor or profiles on the pit edge. In the chassis, the pit jacks can be moved between the left and right edges of the pit.

As the freely movable chassis is already movable in all directions thanks to four swivel rollers, the pit jack is permanently mounted on this chassis.

Basically, each jack consists of a drive, hydraulic block, oil tank and cylinder.

The pit jacks are divided into single-stage, two-stage and three-stage, depending on the number of cylinder stages, and into manual-hydraulic, pneumatic-hydraulic and electro-hydraulic drive types.

Manual hydraulic pit jacks are equipped with a high-pressure or low-pressure hand pump, depending on the required load. The low-pressure hand pump has a larger pump cross-section and therefore a larger delivery volume. Due to its

smaller pump cross-section, the high-pressure hand pump offers the possibility of achieving higher hydraulic pressures and thus also lifting heavier loads.

With pneumatic-hydraulic pit jacks, the compressed air is used to drive an air motor that is firmly bolted to the hydraulic block. This oscillating pressure intensifier transports the hydraulic oil.

In rapid traverse, the hydraulic oil in the tank is pressurized with compressed air, which displaces the hydraulic oil from the tank and allows the lifting piston to reach the load application point more quickly.

The telescopic pit jacks are based on the synchronization principle of all telescopic stages.

An overflow system is installed for automatic Bleeding of the single-stage pit jacks.

The pump block contains load, suction and overload valves. The low-pressure foot pump is installed according to the spare parts list. The self-closing lowering valve is also mounted on the pump block.

An attached support plate (claw/gear plate) serves as the load suspension device.

For special load application points on vehicles, other suitable mounts from our range of accessories can be fitted.

The safe use of these optional load handling attachments is not covered by these operating instructions, but is described in separate operating instructions supplied with the load handling attachment.

5 Safety devices

5.1 Pressure relief valve

A pressure relief valve is installed between the pump and the non-return valve. This pressure relief valve limits the hydraulic pressure that can be generated by the pump and thus prevents loads that are too heavy from being lifted. The pressure relief valve is adjusted to the load capacity and set at the factory. This setting must not be changed.

5.2 Self-closing drain valve

With the electro-hydraulic pit jack, the lowering valve is opened via the "Lower" button. The lowering speed can be adjusted using the rotary knob. The operating elements are self-resetting, i.e. the lowering valve closes automatically when the button is released.

All other types are equipped with a drain spindle that opens the drain valve by turning it counterclockwise. When the drain spindle is released, a spring closes the valve automatically.

5.3 Overflow device for limiting the end position of the cylinders

The manual single-stage pit jack MPJ 1S and the pneumatic pit jacks are equipped with an overflow device. When the end position of a cylinder stage is reached, a bypass opens and prevents the cylinder stage from being extended further and leaving the guide.

On all other pit jacks, the travel of the cylinder stages is limited by a mechanical stop.

5.4 HAE main switch

The electro-hydraulic pit jack has a main switch. If this is turned to "0", the power supply to the pit jack is switched off. The main switch also functions as an emergency stop.

6 Technical data

6.1 Relevant pit dimensions

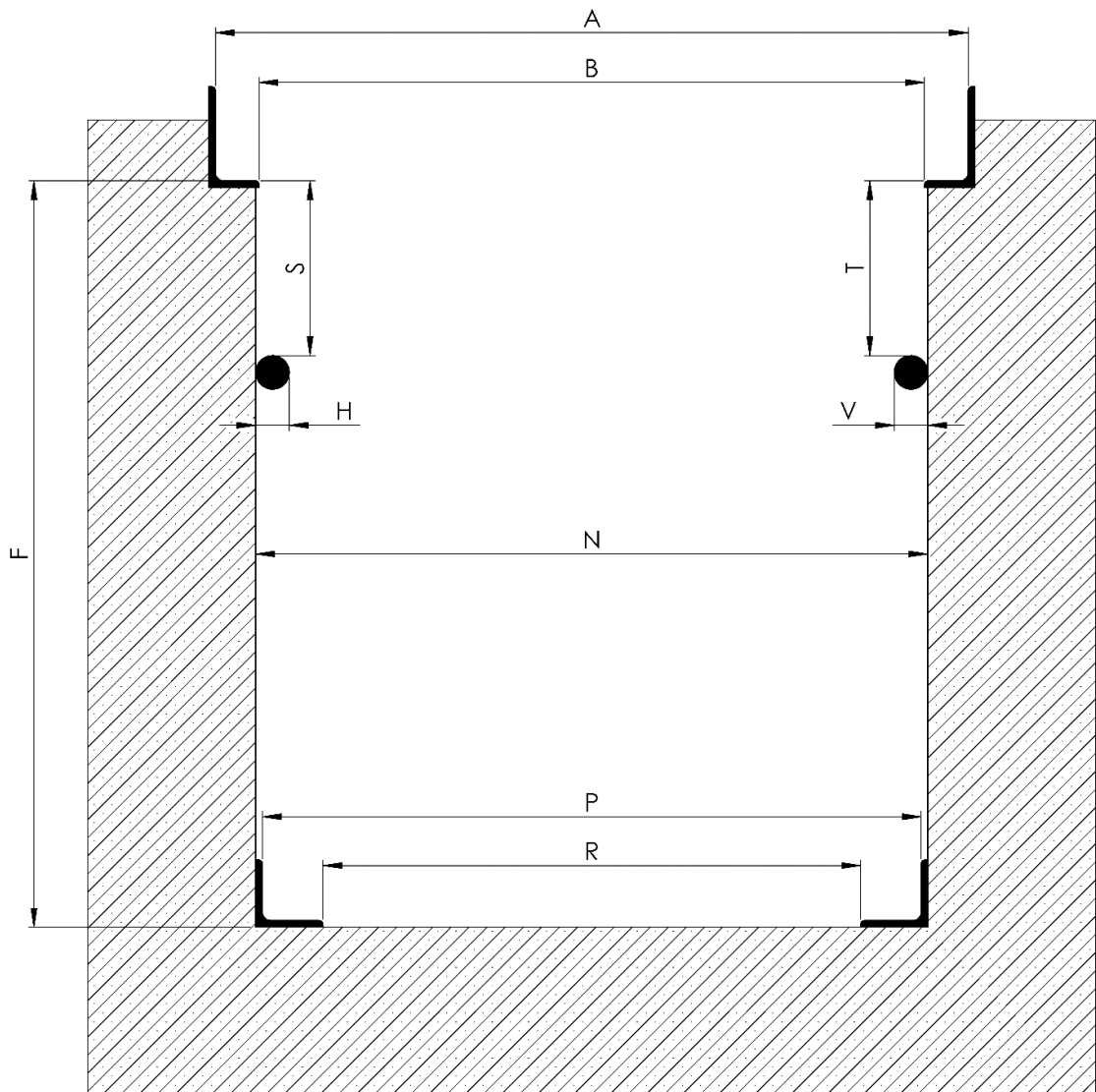

6.2 Nomenclature

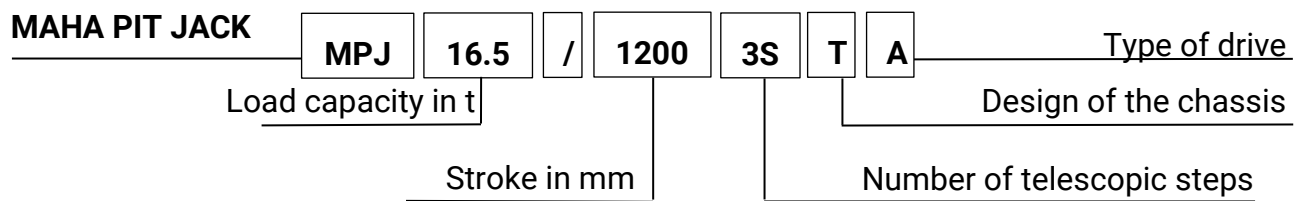

Telescopic steps:

S - Number of telescopic steps

Design of the chassis:

H - Suspended version F - "Floor" = Floor-running, freely movable version T - "Track" = Floor-running, rail-guided version

Type of drive:

M - Manual operation with hand pump

A - Automatic operation with rapid control and air motor

E - Electro-hydraulic drive

6.3 Pit jack

	MPJ 4.0/750 1S HM	MPJ 4.0/750 1S HA	MPJ 16.5/750 1S HM	MPJ 16.5/750 1S HA	MPJ 16.5/750 1S FA	MPJ 16.5/750 1S TA	MPJ 16.5/750 1S HAE	MPJ 20/750 1S HM	MPJ 20/750 1S HA	MPJ 20/750 1S FA	MPJ 20/750 1S TA	MPJ 16.5/1200 2S FA	MPJ 16.5/1200 2S TA	MPJ 16.5/1200 2S HA	MPJ 16.5/1200 3S FA	MPJ 16.5/1200 3S TA	
Load capacity [kg]	4000		16 500						20 000				16 500				
Inside diameter of mounting (spigot) [mm]	30		45						45								
Outer diameter (piston rod) [mm]	45		70				90	70			80						
Dead weight of pit jack [kg]	75		120				145	120			210						272
Max. Tare weight with chassis [kg]	210		260		215	410	285	230		215	410	300	510	410	362	572	
Actuator 8...max. 10 bar at 350 L/min	-	x	-	x	x	x	-	-	x	x	x	x	x	x	x	x	
Drive 2.5 kW, 3 x 400 V, 50 Hz, 16A	-	-	-	-	-	-	x	-	-	-	-	-	-	-	-	-	
Operating pressure [bar]	159		254					308			240		195				
Stroke [mm]	750											1200					
Noise emission [dB (A)]	<70											<78					
Operating temperature [°C]	+ 5...40																
Hydraulic oil type HLP-D	10						22	10									
Hydraulic oil quantity [liters]	3.3	9.5					14.5	9.5			15.8		28				
Lifting speed [mm/s] load-free							22										
Lowering speed [mm/s] load-free							31										

6.4 Chassis

The running rails for chassis must be made of solid steel profile. Flat steel, L, U or I profiles are suitable. The running rails must be firmly connected to a load-bearing substrate and must not exceed a maximum gradient of 2° in any direction.

The two running rails must be straight and parallel in terms of track width and gradient.

6.4.1 Suspended chassis

Suspended chassis run on steel profiles at the edge of the pit and bear the code letter "H" (vlg. Nomenclature). For detailed dimensions see appendix

Overview

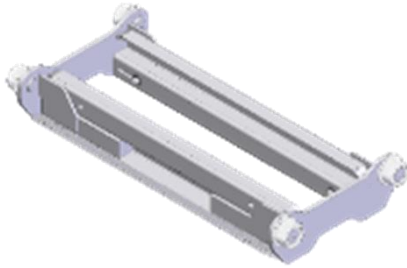

For pit jacks up to and including 16.5 t
Track width +/- 70 mm adjustable
Cylindrical or conical rollers

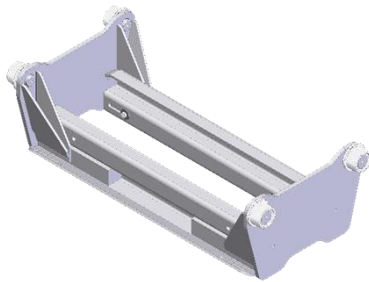

For pit jacks up to and including 16.5 t
Track width +/- 70 mm adjustable
Cylindrical or conical rollers

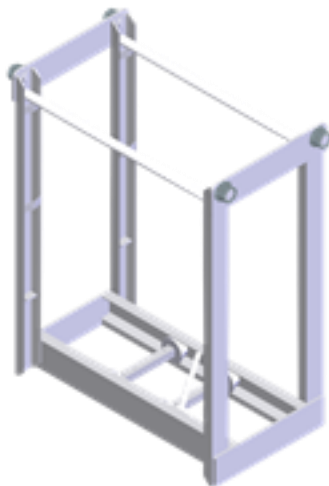

For pit jacks up to and including 16.5 t
Track not adjustable
Cylindrical or conical rollers

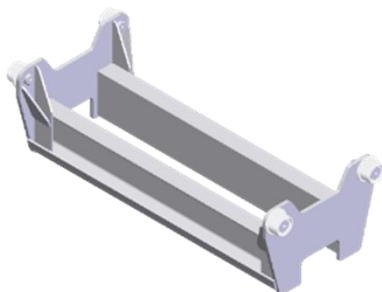

For pit jacks up to and including 20 t
Track not adjustable
Cylindrical or conical rollers

6.4.2 Rail-guided chassis

Rail-guided chassis run on steel profiles on the pit floor and bear the identification letter "T" (vgl. Nomenclature). See appendix for dimensions.

Overview

For pit jacks up to and including 16.5 t

Adjustable track

Cylindrical or conical rollers

Internal or external rollers



Internal chassis roller

Cylindrical shape

With guide collar

Suitable for flat steel min. 75 x 10 mm

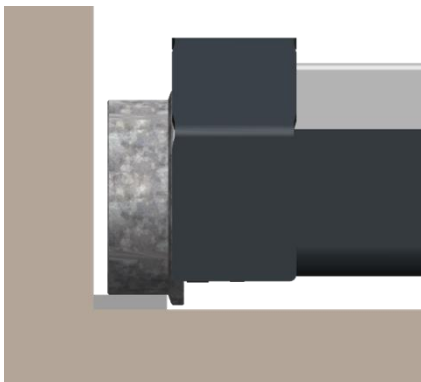

External chassis roller

Cylindrical shape

With guide collar

Suitable for flat steel from 50 x 10 mm

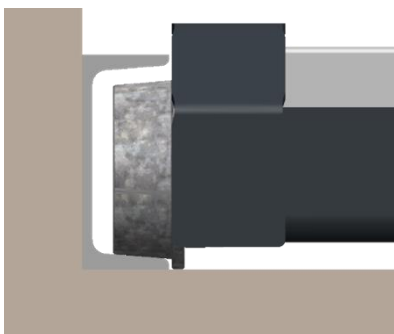

External chassis roller

Conical shape with 8% inclination

With guide collar

Suitable for U-profile from U160

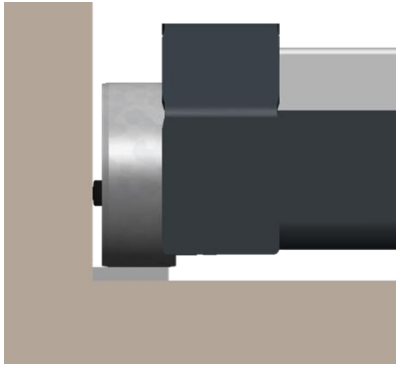

External chassis roller

Cylindrical shape

Without wheel flange - only with roller for guidance on the pit wall

Suitable for flat steel from a width of 55 mm

6.4.3 Freely movable chassis

Freely movable chassis run on the pit floor or outside the working pit and bear the code letter "F" (vlg. Nomenclature).

- 2 of the 4 swivel rollers are fitted with brakes.
- Lowers to the floor from a load of approx. 1000 kg by means of a pre-tensioned spring.

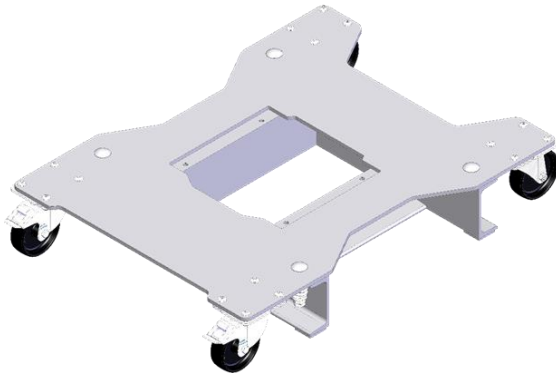

6.5 Permitted pit jack-chassis combination

Load capacity	Lifting distance	Telescopic stages	Driving range				Drive			Model		
MPJ for cars and vans												
4.0 t	750 mm	1S			H			M		MPJ 4.0/750 1S HM		
					H			A		MPJ 4.0/750 1S HA		
MPJ for trucks and buses												
16.5 t	750 mm	1S				F			A	MPJ 16.5/750 1S FA		
							T		A	MPJ 16.5/750 1S TA		
					H			M			MPJ 16.5/750 1S HM	
					H					A	MPJ 16.5/750 1S HA	
					H					A	E	MPJ 16.5/750 1S HAE
	1200 mm	2S				F			A		MPJ 16.5/1200 2S FA	
							T		A		MPJ 16.5/1200 2S TA	
					H					A		MPJ 16.5/1200 2S HA
							F			A		MPJ 16.5/1200 3S FA
					3S				T		A	
MPJ for heavy goods vehicles												
20.0 t	750 mm	1S				F			A	MPJ 20.0/750 1S FA		
							T		A	MPJ 20.0/750 1S TA		
					H			M			MPJ 20.0/750 1S HM	
					H					A		MPJ 20.0/750 1S HA

6.6 Danger zone



WARNING

No persons may be in the danger zone during the lifting or lowering process.

The danger zone is defined as the pit jack incl. test vehicle plus the safety distances specified in the following table.

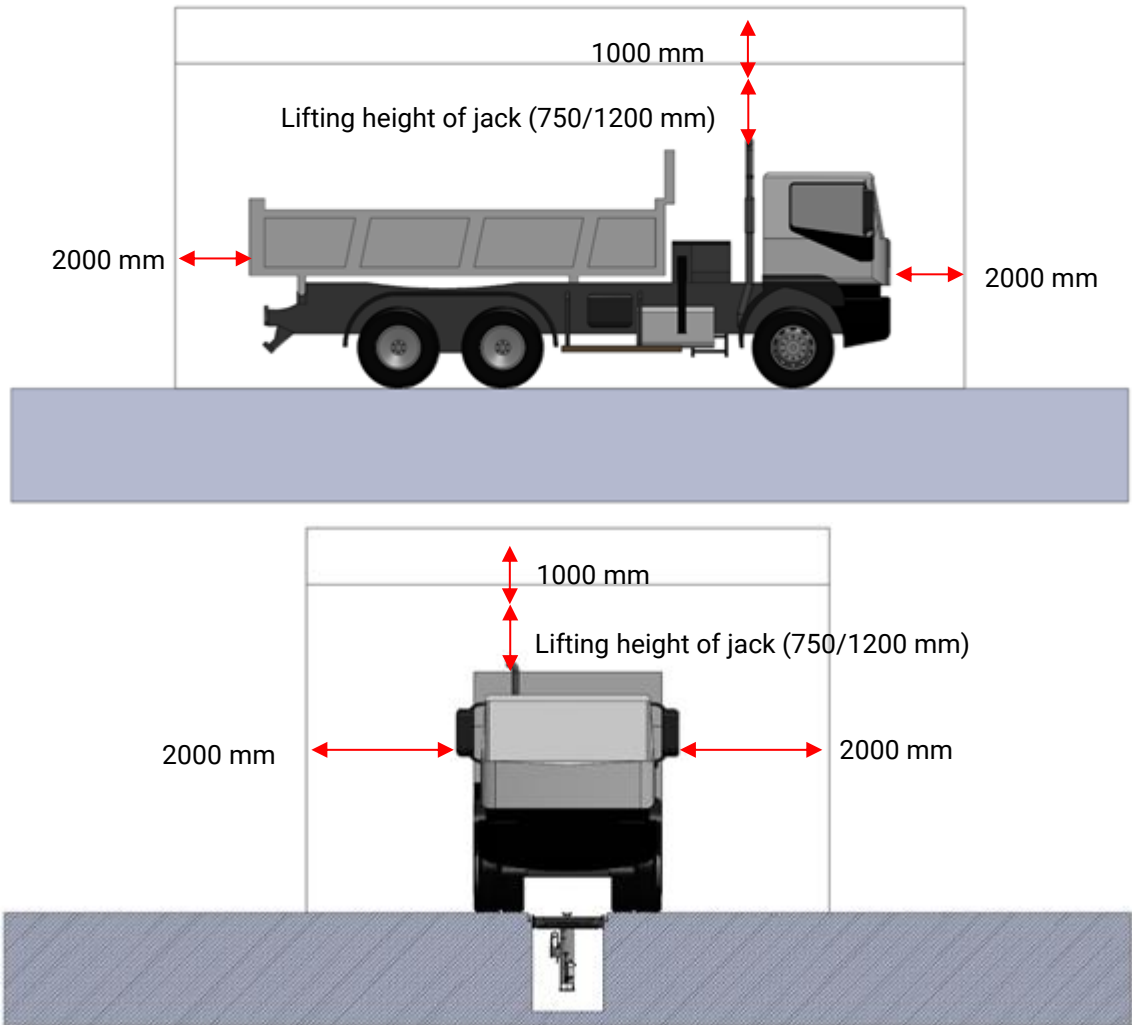

Spatial boundaries	Safety distances
Front	Vehicle + 2 m
Rear	Vehicle + 2 m
Lateral	Vehicle + 2 m
Top	Vehicle + lifting height jack + 1 m

7 Transport, handling and storage

7.1 Safety instructions



WARNING

Wear personal protective equipment.

Standing under a suspended load is prohibited.

The transport and storage of packages is only permitted using original transport racks. Observe the max. stacking height.

Before removing the packaging straps, secure the packages against falling and maintain a safe distance.

Take care when unpacking the pit jacks. Rebounding packaging straps can cause injuries!

For loading, unloading and transport, always use suitable lifting equipment, load handling devices (e.g. crane, forklift truck) and correct load attachment devices and lifting accessories.

Only use lifting equipment and slings that are suitable in terms of type and permitted load capacity.

Always ensure that the parts to be transported are suspended or loaded properly and in a fall-proof manner, taking into account their size, weight and centre of gravity. Observe transport regulations.

Strapping of the package is not permitted

Stacking of packages is not permitted.

7.2 Scope of delivery

Each pit jack is shipped ex works together with the corresponding chassis in a single package as standard. In some cases, the delivery may consist of two packages due to size or weight. These include:

- Pit jack
- Chassis

The number of delivered packages and contents must be checked for damage and completeness according to the order confirmation. Any transport damage must be documented immediately and reported to the delivery carrier.

7.3 Packaging information

Delivery is always on Euro pallets (800 mm x 1200 mm).

Max. Dimensions of the package (L x W x H): 1593 x 1026 x 1145 mm

Max. Weight of the package: 572 kg

The center of gravity of the packages is located within the base area of the Europallet.

7.4 Transport and handling

Check the scope of delivery for completeness in accordance with the order confirmation. Report any transport damage to the carrier immediately.

As the pit jacks are shipped on Euro pallets, they can be moved with all standard industrial trucks and crane forks.

The dimensions and center of gravity of the packaged pit jacks are shown in the section "Packaging information".

7.5 Storage

The packages must be stored in a covered location and protected from direct sunlight. They must be stored at low humidity and at a temperature between +5 °C and +40 °C.

The packages must not be stacked. Packaging waste must be disposed of in accordance with applicable environmental regulations.

8 Installation

Air pit jacks may only be operated with dry, lubricated compressed air in accordance with ISO 8573-1:2010 [1:4:2].

To ensure the required compressed air quality, which is necessary for reliable operation of the pit jack, a maintenance unit must be installed in the supply line in the immediate vicinity of the pit jack (line length max. 5 m).

See also section "Maintenance unit".

This maintenance unit must consist of a compressed air filter, water separator and oil nebulizer. These components are necessary to prevent damage to the pit jack, e.g. due to corrosion.

NOTICE

A refrigeration dryer is not enough for compressed air maintenance! A refrigeration dryer cannot filter out line dirt and does not supply the appliances with the oil film that is important for trouble-free operation.

8.1 Safety instructions



WARNING

Installation may only be carried out by authorised and trained specialist staff.

Such specialist staff include authorised, trained specialists employed by the manufacturer, the authorised dealers and the relevant service partners.

At least one second person must be called in to support the assembly work, and if necessary other persons must also be called in.

Work on the electrical installation may only be carried out by qualified electricians.

Personal protective equipment must be worn for all work.

Work may only be carried out with suitable tools. Use a wrench with a suitable width across flats for screws and nuts.

Where reference is made to the use of special tools, these must be used.

For transportation and handling, hoists with suitable lifting gear (hook with safety latch) and lifting gear (chain slings) must be used.

When threading the chassis into the pit, use slings of different lengths if necessary to prevent the chassis from slipping when tilted.

8.2 Assembly of the rail-guided chassis

- 1 Remove all packaging from the pit jack and chassis.

NOTICE

The chassis is matched to the pit specified in the order. Use in other pits is only permitted after consultation with MAHA.

- 2 For occupational safety reasons, the jack must be disconnected from the chassis during the installation process. To do this, remove all four hexagon head screws (A). When using the telescopic pit jack, ensure that the cover of the operating unit is secured.
- 3 Using suitable lifting gear, lift out the pit jack in an upright position as it sits in the chassis and set it down on level ground.

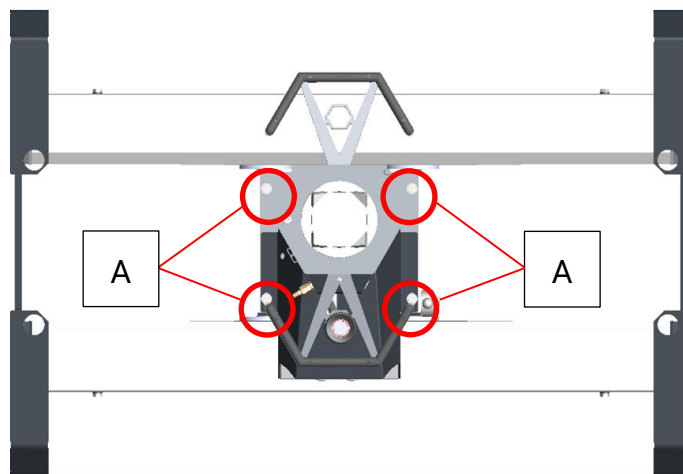

- 4 Secure the freely movable pit jack axles against uncontrolled movement in the chassis, for example by fixing them to the side panel with cable ties.
- 5 Lower the chassis into the pit using suitable lifting gear.

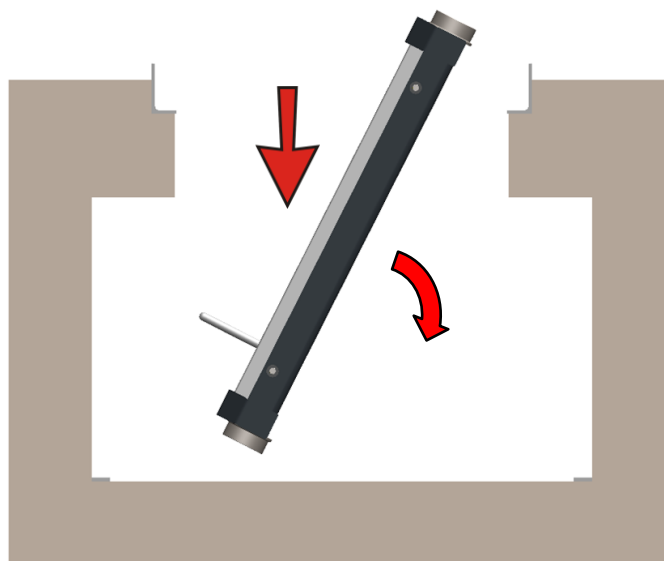

- 6 Set the adjustable side parts of the chassis to the respective pit dimensions. To do this, loosen the hexagon head screws (B). Make sure

that both side sections are extended as far as possible (see dimension "X"). Secure pull-outs with hexagon head screws (B). Set a tightening torque of 50 ± 5 Nm.



- 7 Lower the pit jack into the pit using suitable lifting gear.
- 8 Mount the pit jack on the chassis in the reverse order to disassembly. Tighten the four hexagon head screws (A) to fix the pit jack with a tightening torque of 85 ± 5 Nm.
Note that the collar of the chassis rollers or the entire chassis in particular must be able to move freely over the entire length of the pit.
For the chassis variant with cylindrical flangeless rollers (see section "Rail-guided chassis"), now adjust the deflector rollers to the pit width and tighten the screws (C). The chassis rollers must run safely on the rails along the entire length of the pit.

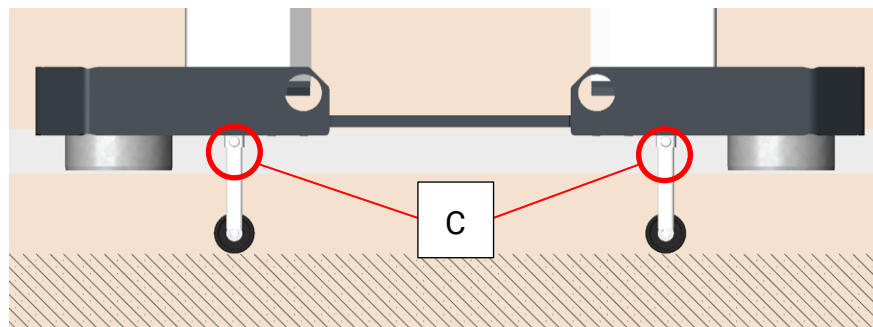

8.3 Mounting pit jack in suspended chassis

8.3.1 Adjustable chassis up to 16.5 t

Required aids and tools

- Lifting gear (overhead crane, forklift, etc.)
- Torque wrench up to and including 85 Nm
- 2 round slings
- Socket wrench with socket A/F 19
- 2 lashing straps

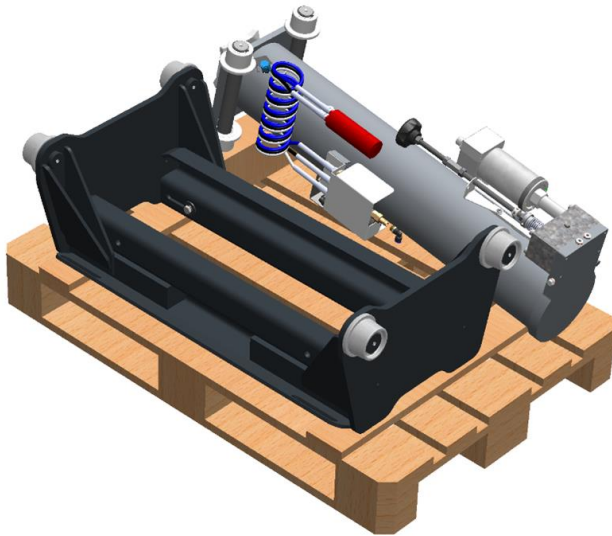

Delivery state

- 1 Attach a round sling tied to the front lifting rollers. Then lift the pit jack off the pallet and place it on **level** ground. Remove the round sling.

Attention: Danger of tipping!

- 2 Remove the transport lock and fit the compressed air line.

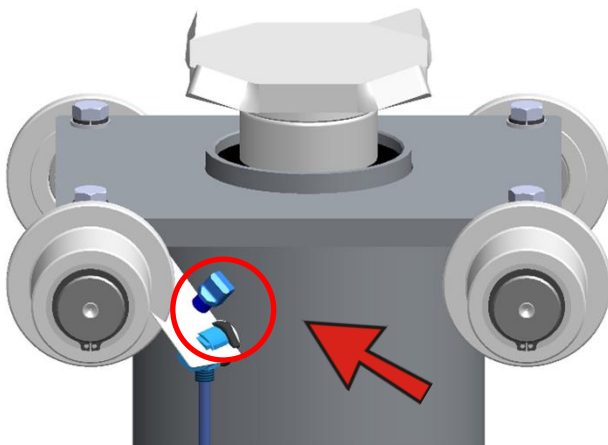

- 3 Remove and store the four M12 screws including washers in the chassis. Then pull out the side panels using lifting gear and place them next to the pit jack.

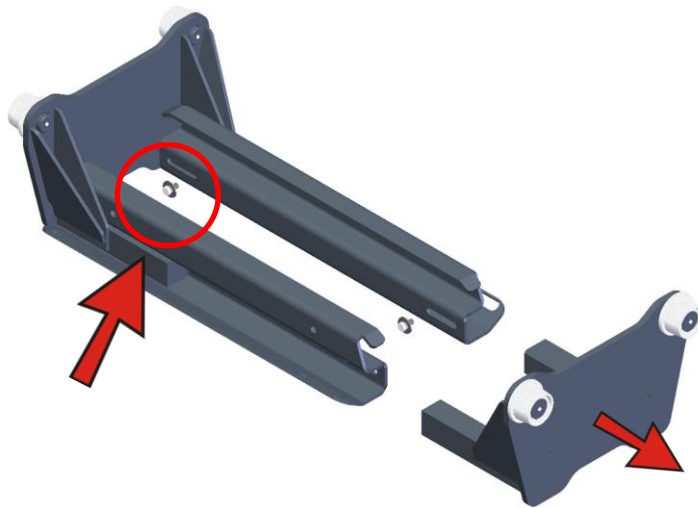

- 4 From this step onwards, at least a second person, and if necessary other persons, must be called in to assist with the installation work. Slide the chassis supports sideways onto the lifting rollers (Caution: Danger of tipping!) and secure with lashing straps. Make sure that the lashing straps are positioned as close as possible to the lift.

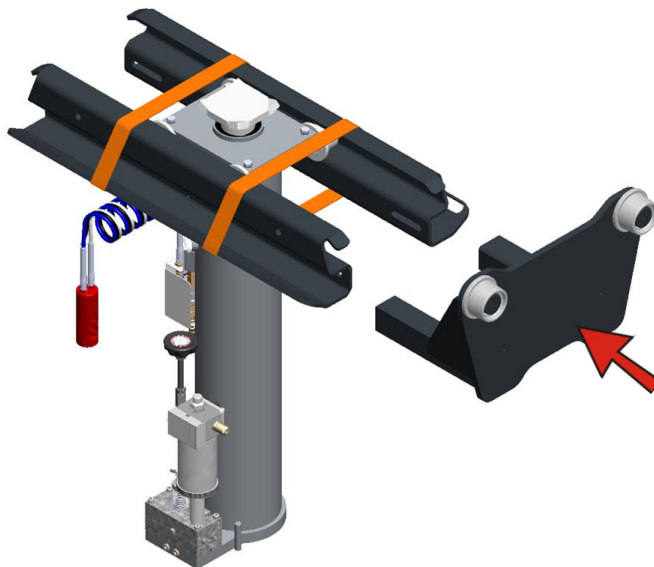

- 5 Fasten one side panel with a round sling, lift it using lifting gear and slide it laterally with the square pins into the chassis beams as far as it will go. Then replace the previously removed M12 screws including washers and tighten them hand-tight.

Align already mounted chassis components load-symmetrically on the jack, i.e. the center of gravity (not the center!) should be aligned centrally above the jack. Attention: Danger of tipping!

- 6 For the second side panel, repeat the installation procedure as described above, see point 5. After inserting the second side part, reposition the chassis centrally on the lift.

The jack is now centered in the chassis and can now be secured against slipping. Two lashing straps are recommended, which are guided through the handle openings in the carriers and enclose the lift in opposite directions.



- 7 Attach the sling diagonally to two sling rolls with a round sling. Then lift the jack including chassis using lifting gear and lower it into the center of the pit. The side panels must be inserted for this.

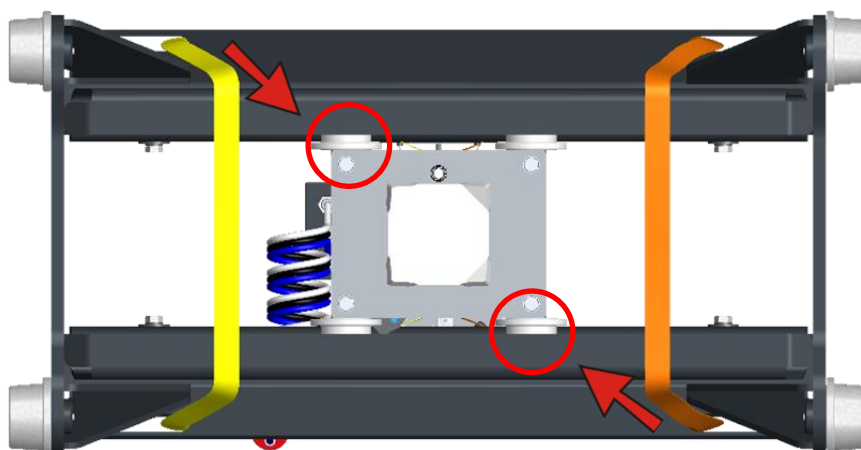

Align the lift in the L-profile or in the U-profile depending on the installation situation. If necessary, the chassis can be tilted for this purpose if the securing described in step 6 has been carried out correctly using lashing straps.

- 8 Loosen M12 screws on one side panel until the washer can be turned freely. Now pull out the side part until the frets of the chassis rollers are in contact with the pit profile. Repeat the process with the second side panel. Make sure that both side parts are extended to the same extent so that the carriers are positioned symmetrically in the middle between the side parts. Tighten the hexagon head screws on both side parts to a tightening torque of 85 ± 5 Nm. Check the central alignment of the chassis. Remove the round slings and push the lift through the entire working pit. At the widest point of the working pit, the clearance between the roller collar and the pit profile may be 5 mm on both sides (max. 10 mm permissible on one side). Then remove the lashing straps from the lift.

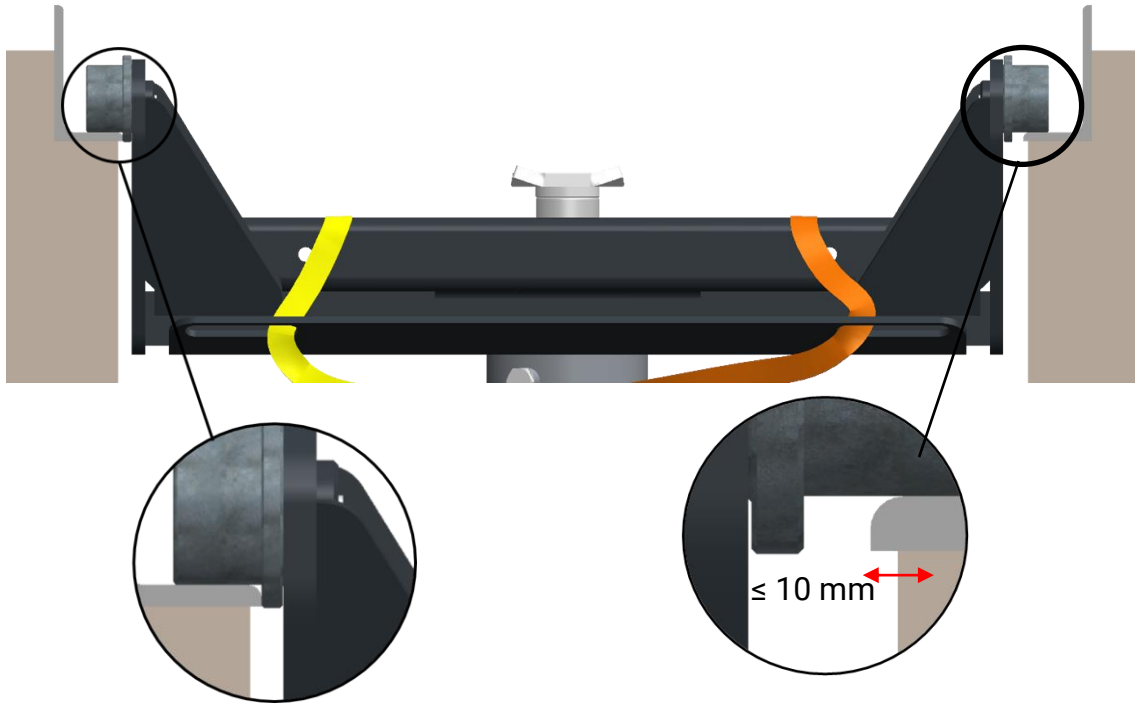

8.3.2 Customized chassis 20 t

The chassis for load capacities of 20 t are welded to size, i.e. no side sections can be moved or beams removed. Observe the installation procedure described in the section "Installation of suspended chassis". The same aids and tools are required. Deviating from this, the following assembly steps must be performed.

Attach the pit jack with a round sling to the front lift rollers. Then lift the pit jack off the pallet and place it on **level** ground. Remove the round sling. **Attention: Danger of tipping!**

Remove the transport lock and install the compressed air line.

Remove the jack axes including rollers by loosening the four M12 screws on the jack support plate (see illustration).

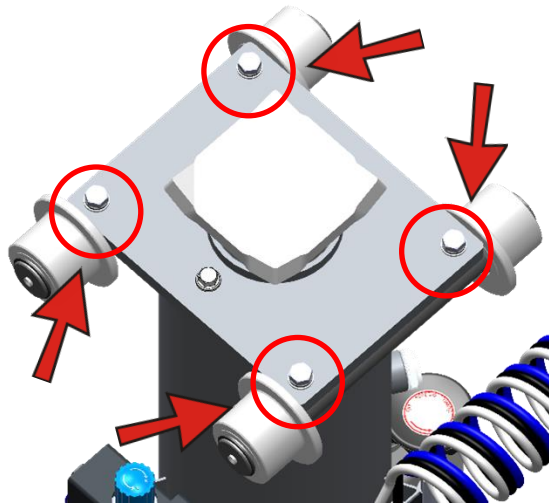

Raise the chassis using suitable lifting gear so that it cannot tip over and lower it over the pit jack until the top plate is approx. 90 mm above the running surface of the chassis. Then fit the lifting axes including rollers (see illustration). Tighten the screws to 50 ± 5 Nm.

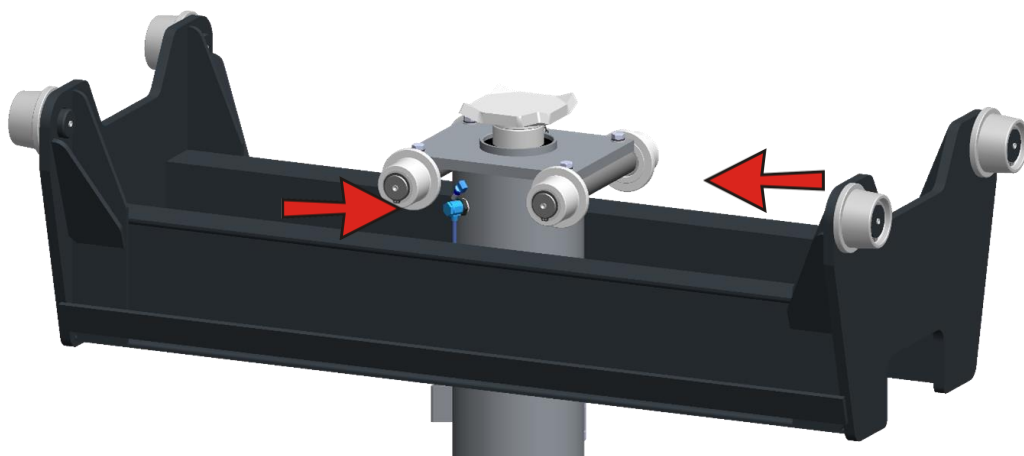

Raise the chassis so that the jack is still firmly positioned on the ground and the chassis rollers are already in contact with the chassis. Now follow the procedure for securing the jack described in step (6) in the section "Mounting the suspended chassis". As the made-to-measure chassis do not have handle openings, we recommend wrapping the side section. Note the central alignment

of the lift and the counter-rotation of two lashing straps to prevent the lift from slipping. **Attention: Crushing hazard**

After securing the jack in the chassis, it can be inserted into the pit (use the existing pit opening). Push the pit jack through the entire working pit. At the widest point of the working pit, the clearance between the roller collar and the pit profile may be 5 mm on both sides (max. 10 mm permissible on one side).

8.3.3 Customized chassis up to 16.5 t for telescopic pit jacks

Remove all packaging from the pit jack and chassis.

For safety reasons, the jack must be disconnected from the chassis during the installation process. To do this, remove all four hexagon head screws (A). When using the telescopic pit jack, ensure that the cover of the operating unit is secured.

The two reinforcement tubes (B) can be removed upwards for installation.

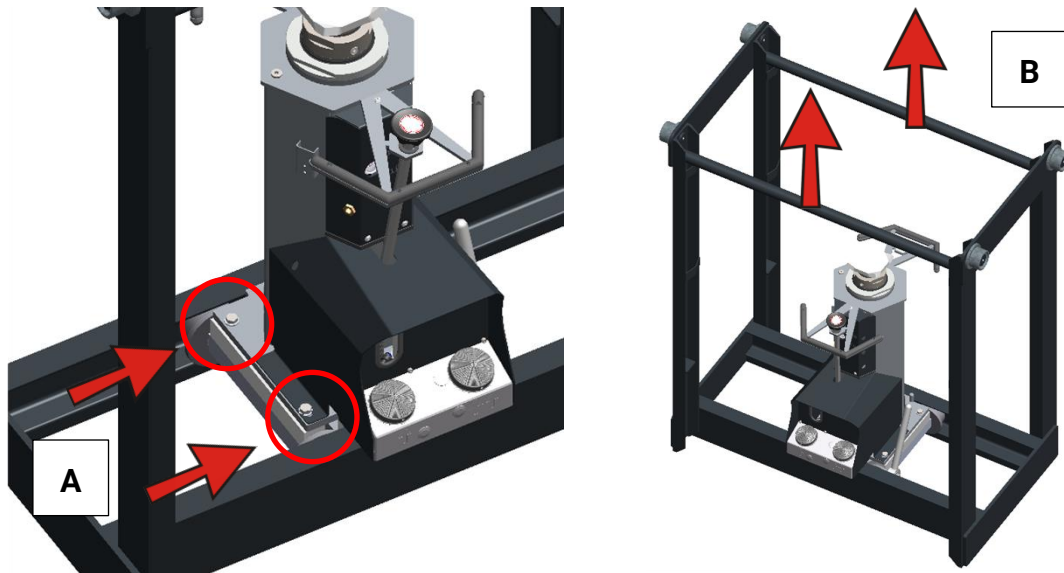

Using suitable lifting gear, lift out the jack in an upright position as it sits in the chassis and set it down on level ground.

Secure the freely movable pit jack axles against uncontrolled movement in the chassis. For example, fix them to the side plates using cable ties.

Lift the chassis with suitable lifting gear so that it cannot tip over and lower it into the pit. It is recommended to attach the chassis at four points (C) on the inside.

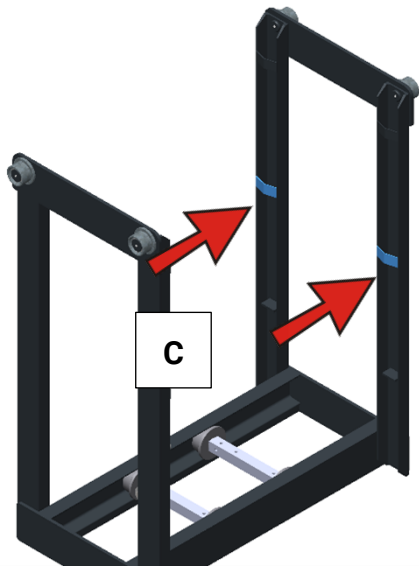

- 1 Lower the pit jack into the pit in an upright position using suitable lifting gear.
- 2 Mount the jacks on the chassis in the reverse order to that for disassembly. Tighten the four hexagon head screws (A) to fix the pit jack with a tightening torque of 85 ± 5 Nm.
- 3 Reinsert the reinforcement tubes
- 4 Push pit jack through the entire working pit. At the widest point of the working pit, the clearance between the roller collar and the pit profile may be 5 mm on both sides (max. 10 mm permissible on one side).

8.4 Floor-running chassis

- 1 Pit jack or gearbox jack are fully assembled in the chassis.
- 2 Remove the packaging and attach the pit jack incl. chassis to the head plate using two round slings (see illustration).
- 3 Lift the pit jack from the Europallet and move it to its destination (pit/floor).

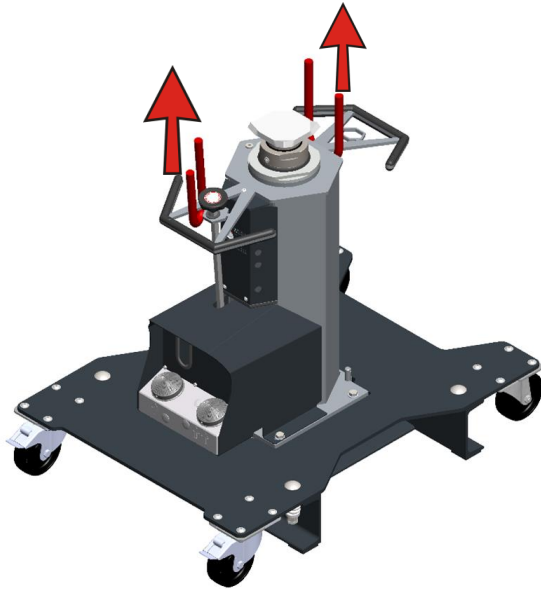

9 Optional equipment

9.1 Optional load handling attachments

Caution: When using optional load handling attachments, the relevant operating instructions must be observed in addition to these instructions.

Irrespective of the operating instructions for optional load handling attachments, the following safety instructions must always be observed.

- Support tubes must not be extended. Danger of tipping!
- There is a risk of crushing between the edge of the pit and the support bridge.
Lower the load with extreme caution
- Support systems may only be removed when there is no load and the load is stable
- Note the change in the load's center of gravity, e.g. with different fuel quantities in an asymmetrical fuel system. Use suitable lifting gear as required.
- Observe the operating instructions for all devices and tools used.
- Check load handling attachments carefully for operational safety.
- Pre-position the lifting device and load handling attachment at the pick-up points.
- Always pick up the load securely, without slipping and centrally to the center of gravity.
- Position the adjusting parts, supports and underlays at the support points and, depending on the type, pin the support tubes with bolts and secure them with linchpins or place wooden blocks at least 500 mm apart.
- Lift or lower the load slowly and under constant observation.
- Lower the load safely, without slipping and centrally to the center of gravity.

9.2 Maintenance unit

MAHA offers a maintenance unit for its air-operated pit jacks that additionally supports the air quality requirements.

This maintenance unit can be ordered together with the pit jack, but can also be retrofitted.

The maintenance unit is mounted directly on the air connection of the pit jack and consists of a filter-pressure control valve-oiler combination.

A coarse pre-filter at the compressed air inlet is designed to reduce contamination. A clogged pre-filter can lead to a high pressure drop and reduced performance of the pit jack!

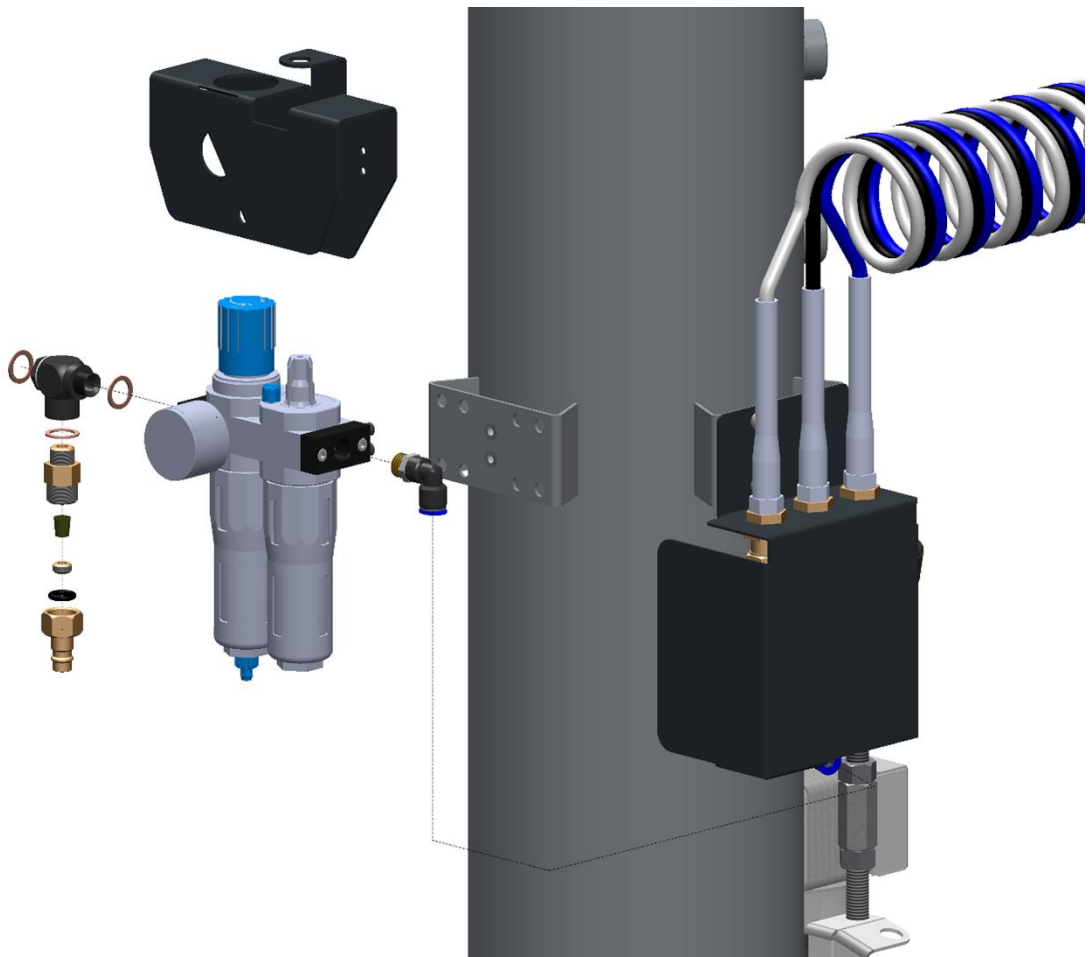

9.3 Special accessories Bleeding

See section "Bleeding".

9.4 Foot pump

The manually operated foot pump enables precise positioning of the load handling attachments under the vehicle or gearbox.

This option is available for telescopic pit jacks. This option can be retrofitted at any time.

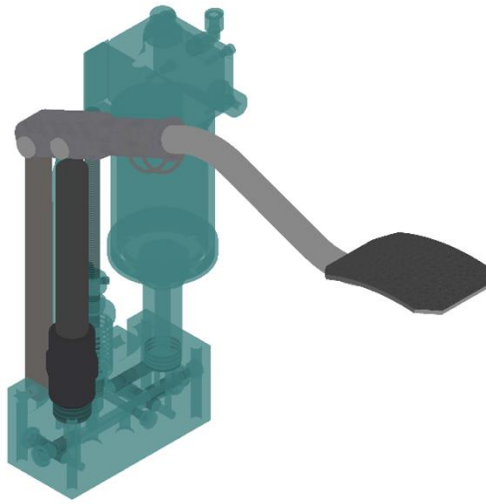

10 Operation

10.1 Control elements

10.1.1 MPJ 1S

The MPJ 1S pit jack series is optionally equipped with a manual pump or a pneumatic-hydraulic pump.

Both variants enable 2 lifting speeds The rapid traverse is very suitable for moving the load handling attachment close to the lifting point unloaded.

The manual pump has two pump pistons for this purpose. The rapid traverse pump displaces a larger volume of oil, but is therefore unable to generate the pressure required for the load stroke.

The load lift pump generates the necessary pressure for this, but this is at the expense of the displaced volume and therefore the lifting speed.

Switching from rapid to load stroke is done by changing the position of the hand lever

The hydraulic-pneumatic pump is driven by an air motor, which in turn drives an oscillating pump piston. This combination generates the necessary pressure to lift the load

Rapid traverse is achieved here by pressurizing the hydraulic oil in the tank with compressed air.

- A Drain spindle
- B Rapid control (automatic via control bottle)
- C Air motor (pneumatically operated)
- D Rapid control (manually operated)
- E Load lift control (automatic via control bottle)
- F Load lift control (manually operated)
- G Pressure relief valve in the hydraulic block
- H Oil dipstick or oil filler plug

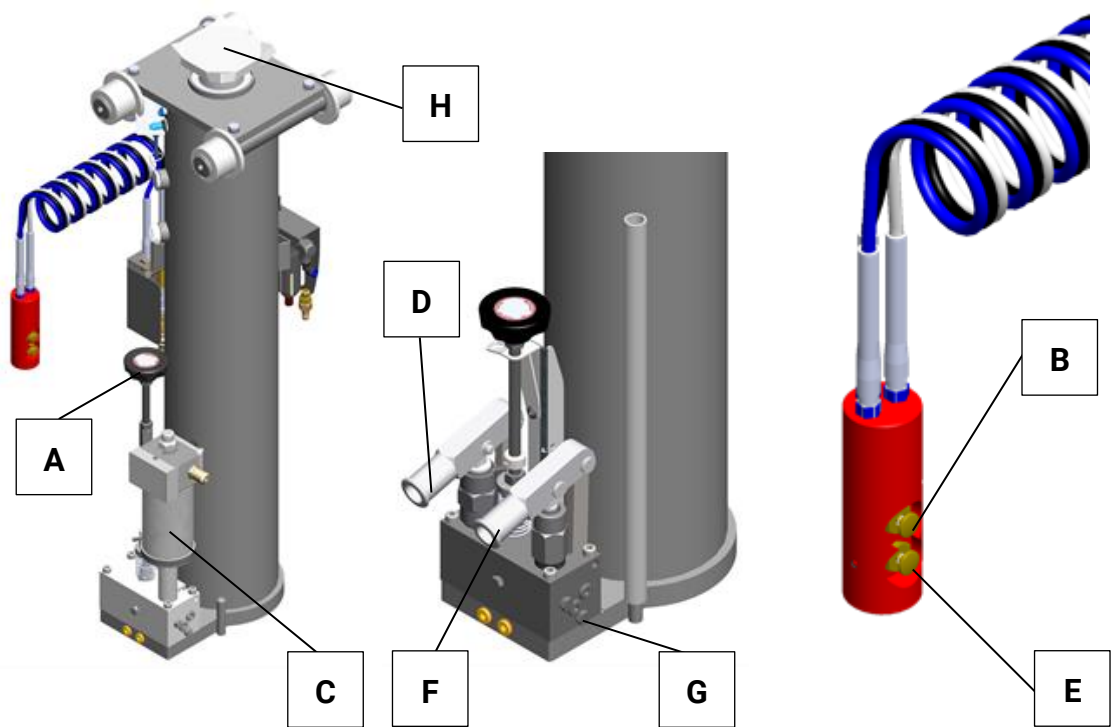

10.1.2 MPJ 2S | MPJ 3S

Standard scope of delivery

- A Drain spindle
- B Maintenance unit
- C Oil filler plug
- D Load lift control (foot-operated)
- E Rapid control (foot-operated)
- F Oil sight glass

Option

- G Foot pump
- H Rapid control (manually operated)
- I Load lift control (manually operated)
- J Foot pedal
- K Hand-held remote control with magnetic holder
- L Quick coupling

Two-stage and three-stage pit jacks differ only in the number of lifting pistons, but not in their operation. The following description applies to both versions.

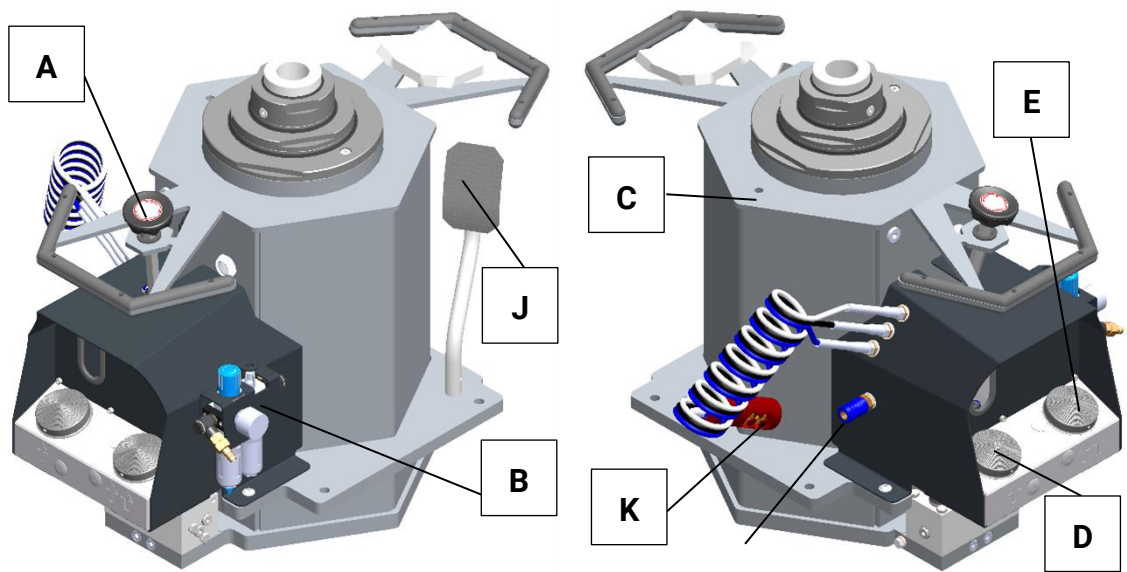
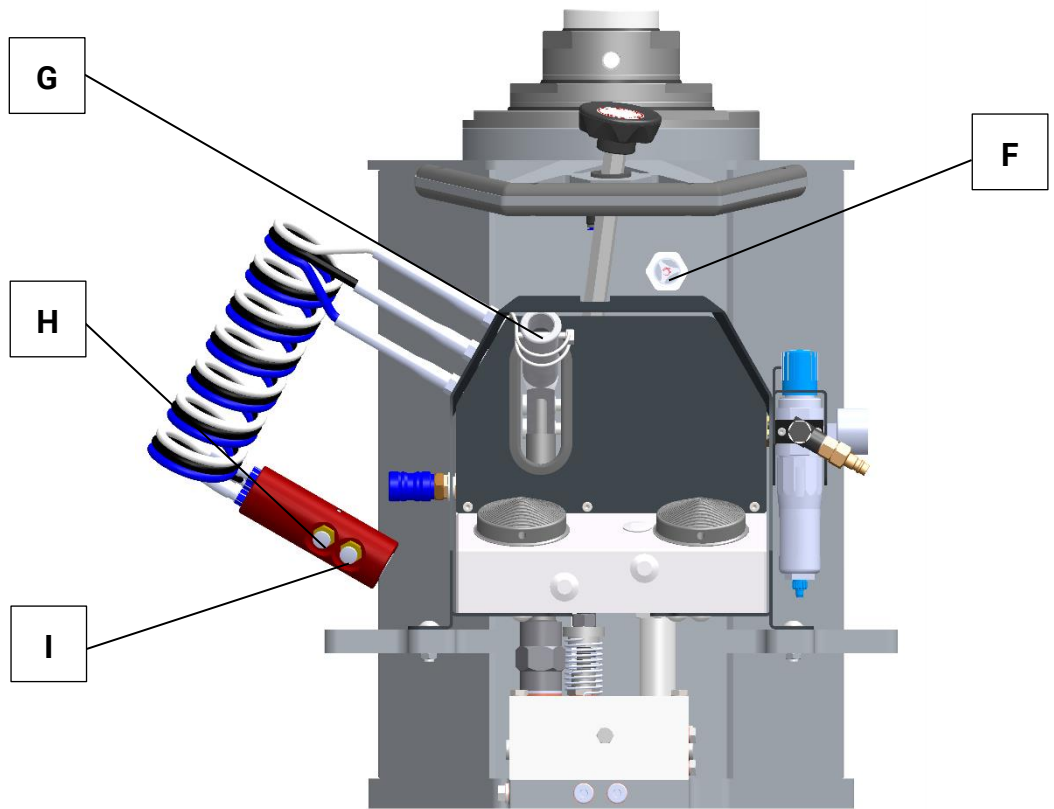

10.1.3 MPJ HAE

The electro-hydraulic pit jack is equipped with a 5 m long cable for the power supply.

To operate the pit jack, an appropriate earthed socket is required within reach of this cable.

- | | | | | | |
|----------|---------------|----------|-------------------|----------|---------------|
| A | Master switch | B | Lift" button | C | Lower" button |
| D | Potentiometer | E | Sheet metal cover | F | Oil tank |

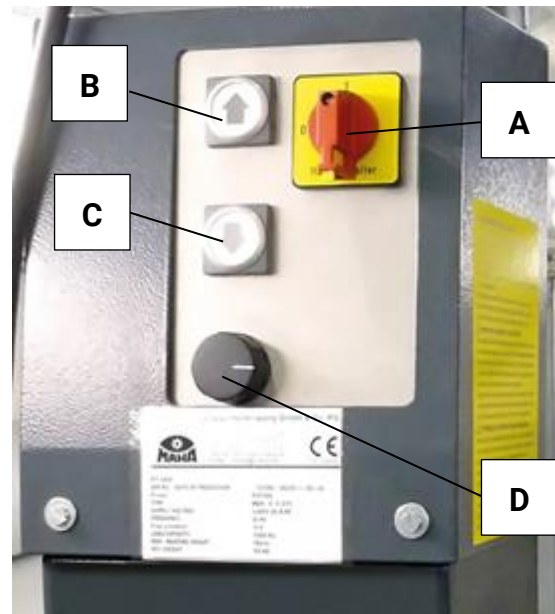
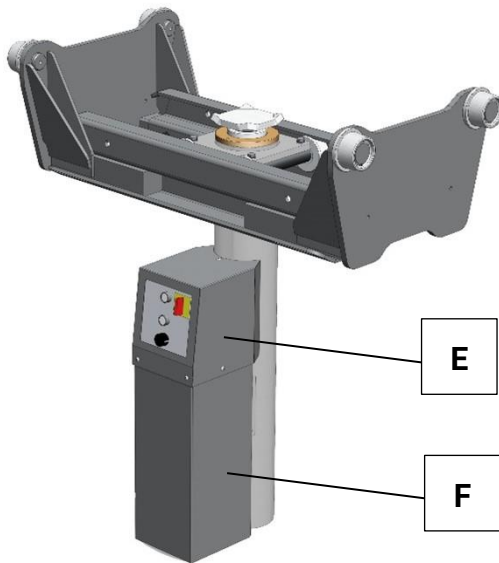

10.2 General safety instructions for safe operation



WARNING

Pit jacks and gearbox jacks are not suitable for supporting the load over a longer period of time. Work under a raised load may only be carried out using suitable supports.

Safety devices must not be bypassed or rendered unusable in any other way.

Riding along with the load or on the load handling attachment is prohibited.

Climbing up the lifted vehicle is prohibited.

Inspection and maintenance intervals must be observed (see section "Inspection and maintenance schedule").

Never use additional lifting gear for an already raised load.

No parts may be placed on the jack or the vehicle to be lifted.

Keep the lift and the working area clean. **ATTENTION: Risk of slipping** on oily surfaces!

Protect all parts of the electrical system from moisture.

Be careful when running vehicle engines.

ATTENTION: Risk of poisoning!

During work breaks and at the end of the working day, the system must be switched off and secured against unauthorized use (e.g. by disconnecting and shutting off the compressed air supply).

If the ground is uneven in the area of the chassis, it must be secured against rolling away.

Load handling attachments must not be deliberately caused to vibrate.

As the chassis is not secured against tipping on the ground, side loading is prohibited.

At the end of work, the pit jacks must be secured against unauthorized use by disconnecting them from the power source. To do this, disconnect the air jacks from the compressed air supply and disconnect the electric jacks from the power supply.

The main switch on the electric pit jack must be set to "0" and additionally secured against being switched on again, e.g. with a padlock.

10.3 Positioning

Positioning safety



WARNING

Before driving into the pit, the jacks must be in the lower home position to prevent damage to the jack and vehicle.

Only drive in the pit at walking speed and only if there are no persons in the pit or on the driveway.

The runway for the pit jack and chassis must be free of dirt.

The pit jack may only be moved with a load when it is retracted. It must be ensured that the load is picked up at the center of gravity and secured in a suitable manner on the load handling attachment (e.g. with lashing straps).

The pit jacks are supplied with a simple holder as standard. MAHA can supply suitable load handling attachments for loads that cannot be lifted safely with these. When using these, the corresponding BAL of the accessory must be observed.

When positioning and attaching to the load, please note that even when the lift button is released, the cylinder can continue to run and extend due to the system.

Move the pit jack under the load when lowered.

Move the load handling attachment close to the pick-up point and wait for the overrun if necessary.

After checking that the load can be picked up safely, secure the jack with the brake in the chassis where available.

After briefly lifting it free, check that the vehicle is securely attached. If necessary, lower the vehicle and pick up again.

10.4 Switch on



WARNING

When positioning and attaching to the load, please note that even when the lift button is released, the cylinder may continue to run and extend due to the system.

MPJ 1S

The manually operated pit jack is always ready for use as it is independent of an external power supply.

MPJ 2S | MPJ 3S

The pneumatic-hydraulic pit jack is ready for use as soon as the compressed air supply is connected.

The specifications regarding compressed air supply must be observed!

MPJ HAE



WARNING

Lay the cable connection to the socket outlet in such a way that there is no risk of tripping.

Ensure that the connection cable is plugged in. To make the pit jack ready for operation, switch on the main switch.
The pit jack is ready for immediate use.

10.5 Lift

Lifting safety



WARNING

The permissible load capacity must not be exceeded.

The load and pit jack must be monitored by the operator during the entire lifting and lowering process. In the event of irregularities, stop the lifting/lowering movement and support the load appropriately.

Maintain a safe distance from the vehicle and lift in all directions.

Keep the movement range of the load and lift free from obstacles. Use a guide if visibility is restricted.

Vehicles doors must be closed during lifting and lowering.

Only loads that are suitable for the lifting equipment due to the shape and position of the lifting points may be lifted.

The load may only be lifted at the component's center of gravity (axle, gearbox, motor, etc.).

The vehicle must be able to roll during the lifting and lowering movement. So that the load can center itself over the pit jack.

The jack must not be used on a surface with an inclination of more than 1°.

If there are height differences between the mounting points, height-adjustable mounts must be used.

Vehicles may only be lifted if the pick-up is undamaged. Risk of vehicle falling and causing personal injury.

The center of gravity may change when installing and removing heavy vehicle components (engine/power units). In this case, suitable measures (determining the center of gravity, checking the pick-up point) must be taken to prevent tipping.

The vehicle or unit must be lashed to the jack if necessary. Shifts in the centre of gravity of the vehicle through installation/removal of heavy vehicle parts may otherwise lead to the vehicle sliding off.

During the lifting and lowering process, there must be no persons or objects in the safety area of the load and pit jack.

Carefully position the load handling attachment on the load during the load stroke and lift it free briefly.

Only lift the load after checking that it is safe to do so.

The vehicle must be able to move freely in the longitudinal direction of the vehicle to prevent the load from slipping.

10.5.1 MPJ 1S

The manually driven pit jack is operated via plug-in pump levers. The distinction between load and fast stroke is made as described above.

The hydraulically-pneumatically operated pit jack is raised by pressing the corresponding button for load or rapid traverse. The buttons are equipped with automatic reset. When the buttons are released, the lifting movement stops automatically.

An attached claw serves as a load suspension device. For special load application points on vehicles, other suitable mounts from our range of accessories can be fitted (support plate, gear plate, axle cross member).

10.5.2 MPJ 2S | MPJ 3S



WARNING

Depending on the air pressure and the lift height reached, the piston rod extends a little further after the button is released.

Risk of crushing between piston rod/load handling attachment and test vehicle.

In the standard version, the pit jacks are supplied with foot control.

The actuating elements for the load and rapid lift are located under a cover at the base of the lift.

The fast approach stroke is located on the right-hand side of the operating field and is indicated by a double arrow. It is used to quickly overcome the dead lift to the vicinity of the lifting point.

From there, you can continue with the load lift. This is located on the left in the operating field and is indicated by a simple arrow.

Sensitive approach to the load lifting point can also be achieved using the optional foot pump. For this purpose, the foot pedal (J) can be inserted into the foot pump (G) and secured against unintentional slipping out by means of a locking pin.

If the pit jack is equipped with an optional manual control, it can also be used for rapid and load lifting. The pushbuttons on the hand control for fast and load lift are marked with a single arrow for load lift and a double arrow for fast lift, just like the foot buttons. The rapid traverse is realized here by pressurizing the hydraulic oil in the tank with compressed air and passing it through a valve that allows a larger hydraulic volume flow.

A strong magnet in the head of the hand control allows it to be securely attached to flat surfaces of the pit jack.

The options are not mutually exclusive, so that all three actuation options are available when fully equipped. The design ensures that none of the three drive options sets another in motion.

The operator must ensure that only one of the three options is used at a time.

10.5.3 MPJ HAE

NOTICE

Drive through quickly and avoid touch operation as far as possible to prevent the motor from overheating. Instead, drive through quickly.

Press button **(B)** to lift.

The respective button is only active as long as it is held down (dead man's switch).

When a move command is triggered, the cylinder moves at a constant speed. There is no rapid traverse control for this pit jack.

10.6 Support

Safety Support



WARNING

Risk of crushing due to lowering the load onto the supports.

After lifting to working height, the load must be supported appropriately.

The operating instructions for the accessories must be observed.

The vehicle must be supported in such a way that shifts in the center of gravity due to the installation or removal of components do not lead to a crash.

When placing the load on the supports, ensure that it rests securely on the supports.

10.7 Lowering

Lowering safety



WARNING

The load must be lowered slowly and carefully to avoid crushing injuries.

Before lowering, the load on the supports must be lifted free in order to remove the supports.

The instructions and procedure for lifting (at the beginning of this chapter) must also be observed for free lifting.

The load and pit jack must be monitored by the operator during the entire lifting and lowering process. In the event of irregularities, stop the lifting/lowering movement and support the load appropriately

10.7.1 MPJ 1S



WARNING

When lowering, the lowering spindle must be operated slowly and carefully to prevent damage to property and personal injury caused by sudden and rapid lowering movements.

With both drive variants, the load is lowered by turning the lowering spindle counterclockwise. A spring acts as an automatic reset. This closes the lowering valve and stops the lowering movement.

When lowering without load, the lowering spindle can be turned counterclockwise as far as it will go. In the case of automatically operated jacks, this actuates the lowering valve and the piston rod is retracted using compressed air.

10.7.2 MPJ 2S | MPJ 3S



WARNING

When lowering, the lowering spindle must be operated slowly and carefully to prevent damage to property and personal injury caused by sudden and rapid lowering movements.

The drain valve is opened by turning the drain spindle counterclockwise. The load pushes the piston downwards. The further this valve is opened, the faster the load drops.

The drain spindle has an automatic reset that closes the valve when released and stops the lowering process.

If the load is on (crossbeam) and the spindle is unloaded, the dead weight of the piston is not sufficient for the jack to lower completely.

If the drain spindle is turned counterclockwise as far as it will go in this

situation, the lowering valve also opens and the lifting piston moves all the way down.

10.7.3 MPJ HAE



WARNING

Before pressing the lowering button, ensure that the rotary switch for changing the lowering speed is set to closed / slow / 0.

The lowering process is initiated by pressing the corresponding pushbutton.

During the lowering process, the lowering speed can be changed using a rotary potentiometer.

MAHA strongly recommends adhering to the following procedure when lowering in order to avoid damage to property and personal injury:

- Set rotary switch to 0
- Press the lowering button
- Hold down the button and check the lowering speed using the rotary potentiometer / rotary knob.

10.8 Moving units onto pit jacks



WARNING

Removed units must be secured on the load handling attachment. If the load cannot be secured by the load handling attachment itself, other measures must be taken (e.g. lashing straps) to prevent injuries caused by the load falling.

Only move the chassis by the handles and only with both hands!

The pit jacks must be moved smoothly, even when starting and braking.

Secure the unit on the jack and lower it as far as possible. Use appropriate load handling attachment to secure the load. Then release the chassis brake and move the pit jack smoothly using the handles. Once the pit jack has reached its destination, secure it against rolling away by applying the chassis brakes.

10.9 Extend



WARNING

Before extending the vehicle, the jacks must be in the lower home position to prevent damage to the jacks and vehicle.

Exit only at walking speed and only if there are no persons in the pit or in the driveway.

ATTENTION: Be careful when running vehicle engines. **Danger of poisoning!**

11 Troubleshooting



WARNING

- The relevant health and safety regulations must be observed.
 - Wear personal protective equipment.
 - Service work may only be carried out by authorised service technicians.
 - Repair, maintenance and set-up work may only be carried out when the machine is at a standstill. The system must be disconnected from the power supply or the compressed air supply must be interrupted and secured against being switched on again.
 - Maintenance and repair work should only be carried out when the lift is load-free.
 - Only use original replacement parts.
 - Substances that are hazardous to the environment must be disposed of appropriately.
 - No high-pressure or steam-pressure devices and no aggressive cleaning agents may be used to clean the pit jacks.
 - The safety devices of the pit jack must be adjusted by authorized service technicians.
 - The safety features must not be replaced or overridden.
-

11.1 Manual/pneumatic-hydraulic pit jacks

Malfunction	Possible cause	Remedy
Air motor runs (typical noise), but does not lift any load	Drain spindle not fully closed; spring does not close completely	Replace drain spindle and/or spring; contact service
	Oil level on the pit jack too low due to transport damage or natural consumption	Top up oil
	Leaking suction valves	Contact service
Air motor runs (typical noise), but does not lift the full load	Drain spindle not fully closed; spring does not close completely	Replace drain spindle and/or spring; contact service
	Overload valve triggers; load too high	Reduce load; observe load capacity
	Leaking load valves	Contact service
Air motor initially runs on idle (typical noise), but becomes increasingly slower under load and then stops completely	Air motor runs dry; no oil in the maintenance unit	Top up oil
	Air pressure too low; local cause	Contact service
Air motor first lifts the load a certain height and then pumps through empty	Oil level on the pit jack too low due to transport damage or natural consumption	Top up oil
Air motor first lifts the load a certain height and then slows down more and more	Air filter clogged; dirt from the pipe network	Cleaning
	Air pressure too low; local cause	Contact service
	Air volume too low; local cause	Contact service
Air motor first lifts the load a certain height and then slows down more and more until it comes to a standstill	Air pressure too low; local cause	Contact service
Air motor runs very slowly even when idling	Air filter clogged; dirt from the pipe network	Cleaning
	Air motor runs dry; no oil in the maintenance unit	Top up oil
	Air pressure too low; local cause	Contact service

Malfunction	Possible cause	Remedy
Air motor does not run at all	Air filter completely clogged; dirt from the pipe network	Cleaning
	Air motor runs dry, stops; no oil in the maintenance unit	Top up oil
	Air motor defective	Replace
Air express control does not work	Air filter clogged; dirt from the pipe network	Cleaning
	Pneumatic control line blocked or kinked	Contact service
Raised load is lowered	Drain spindle not fully closed; spring does not close completely	Close drain spindle; contact service
	Leaking load valves	Contact service
Piston rods extend slowly at first when unloaded and suddenly become faster	Oil level on the pit jack too low due to transport damage or natural consumption	Top up oil
Piston rods "rattle"; inaccurate steering	Oil level on the pit jack too low due to transport damage or natural consumption	Top up oil
	Insufficient pit jack Bleeding	Contact service
Oil loss at piston rod breather	If within limits, there is no fault	Regularly extend to full stroke so that no leakage oil accumulates
Oil loss at valves	Too much oil from maintenance unit	Set lower
	Oil propagation through water from compressed air	Check maintenance unit
Oil leakage at spindle guide	Seal wear	Contact service
Oil leakage at sealing plug	Leaking sealing plugs	Contact service
Oil leakage at the air motor	Too much oil from maintenance unit	Set lower
Oil leakage at the pump block	Seal wear	Contact service

11.2 Electrohydraulic pit jacks

Malfunction	Possible cause	Remedy
Pit jack does not respond	no electricity	Check mains connection
		Check fuses in the control box
Piston rod does not extend	Pump / motor defective	Check pump for running noises
	Control defective	Check connections in the control box (push-button) Replace control box (customer service)
Piston rod only extends without load	Potentiometer defective or position incorrect	Check the position of the potentiometer
		Check connections in the switch box
		Replace potentiometer (customer service)
	Air in the system	Loosen the bleed screw (under the head plate) and press the open button for approx. 1 min
Hydraulic valve / block defective (rare)	Remove the cover, turn the potentiometer all the way to the right, press the up button and check the valve coil for magnetism using a metal object. Turn the potentiometer to the left and check whether the magnetism becomes stronger. If not, check connections and control unit, replace valve coil if necessary	
	Replace hydraulic block (customer service)	
Potentiometer shows no effect (check with load)	Potentiometer defective	Replace potentiometer (customer service)
	Amplifier card defective	Replace amplifier card (customer service)

Malfunction	Possible cause	Remedy	
	Valve / coil defective	Replace valve / coil (customer service)	
	Wrong valve	Check type designation (EMP = prop. Valve)	
Pit jack does not retract or retracts with great difficulty	Wrong valve	Check type designation (EMP = prop. Valve)	
	Hydraulic valve / block defective (rare)	See above	
	Mech. Damage to the pit jack	Check the piston rod and guide bush for visible damage	
		Loosen the bleed screw and observe whether the piston rod lowers. Try to turn the piston rod. If the piston rod can be lowered and rotated, there is no mech. Damage before	
		Customer service	
Seal defective, oil leakage at the guide bushing	Customer service		
Piston rod does not fully extend	Too little oil	Refill oil (HLP-D-22)	
	Air in the system	See above	

12 Regular and recurring inspections



WARNING

All tests must be carried out in an unloaded state.

Irrespective of the periodic inspections, subsequent inspections must be carried out by the operator and user at the specified intervals. Of course, the operator can entrust external experts with these inspections during the year. The same applies to the rectification of any defects identified.

12.1 Daily before operating

To ensure the safety of the system during operation, the following visual and functional checks must be carried out daily before starting work or beginning a shift.

12.1.1 Electrical connections (HAE)

Cables and plugs must be checked for visible damage. If cracks on plugs or cables, bent contact pins on the plug, damaged cable sheathing or similar defects are visible, the affected component must be replaced immediately by a qualified electrician.

The jack must be secured against use until the repair has been completed.

12.1.2 DL - Hoses

Dangerous situations can arise due to hose connections coming loose or porous compressed air lines or malfunctions due to leaks in the air lines and connections.

To avoid this, compressed air hoses and their connections must be checked visually and for audible leaks.

Defective components and connections must be professionally repaired immediately.

12.1.3 Leakage

The pit jack must be checked daily for oil leaks. Check for unusual oil leaks at the piston seal.

Leaking seals must be replaced immediately. If oil leaks from the screw connections on the hydraulic block, the screw connections must be retightened. If oil is still leaking, contact our customer service department and secure the pit jack against further use.

12.1.4 Function drain/locking screw

To check, open the drain spindle and release it abruptly.

The spindle must automatically return to the closed position.

The spindle closes completely when it cannot be closed any further.

Do not apply excessive force when closing to avoid damaging the valve seat.

In this context, check the coil spring for correct seating and damage.

12.2 Weekly

12.2.1 Piston rod

The piston rod must be extended empty once a week (see also Maintenance) to bleed the pit jack.

The piston rod must be checked for damage during this process.

Damaged piston rods lead to leaks in seals.

Damage to the piston rod allows cleaning agents and salt water to penetrate unhindered. Contamination in the hydraulic system leads to undetected damage inside the pit jack.

12.2.2 Pivot of the load suspension

When checking the piston rod, also check the load handling attachment mount.

The bore must be free of impurities and, like the pin on the load handling attachment, must not show any wear or deformation.

Worn or deformed locating holes and pins prevent safe working with the load handling attachment and must be reworked or repaired before the pit jack can continue to be used.

12.3 Every 6 months

12.3.1 Oil level check

NOTICE

For measuring and refilling, the piston rod must be **fully retracted** and the pit jack disconnected from the air or power supply.

- MPJ 1S The oil level must be between the two notches when the dipstick is screwed in. If there is only one notch on the dipstick, this marks the maximum oil level and the lower end of the dipstick marks the minimum oil level.
- MPJ 2S|3S
The oil level must cover at least half of the oil sight glass. If no oil can be seen in the sight glass, hydraulic oil must be topped up.
- MPJ HAE
The oil filler cap or oil dipstick is located under the sheet metal cover in the area of the controls. To check the oil level, it is necessary to remove the sheet metal cover.
The oil level must be between the two notches when the dipstick is screwed in. If there is only one notch on the dipstick, this marks the maximum oil level and the lower end of the dipstick marks the minimum oil level.

12.3.2 Rollers

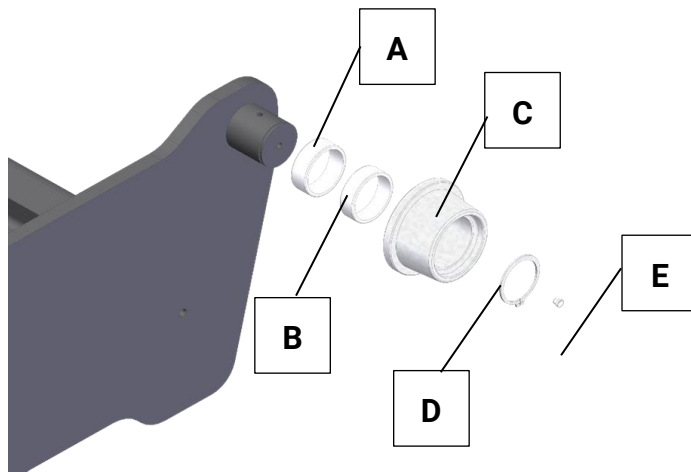

- A Needle sleeve
- B Needle sleeve
- C Chassis roller
- D Circlip
- E Grease nipple Funnel inside and outside

Special attention must be paid to rollers, as they must carry the entire load on the one hand and ensure easy movement of the lift and chassis on the other.

Track rollers must therefore be inspected for deformation and damage to the running surface (chipping, flattening, etc.) and the wheel flange (chipping, burrs, etc.). The needle bearings must also be checked for ease of movement and smooth running by turning the rollers.

Damaged rollers and bearings can no longer perform their task reliably and must be replaced.

Rollers and needle bearings must be replaced together to prevent premature failure.

12.3.3 Movement parts

All moving parts on the pit jack and chassis must run smoothly. This includes not only the above-mentioned rollers.

If necessary, lightly oil or grease the movement points. Dirt and corrosion can impair movement and must be removed.

12.3.4 Lifting brake

The lift brake prevents unintentional movement of the lift in the chassis.

Apply the brake to check. The function is fulfilled when the two flanged rollers on the brake axle of the lever are pressed against the running profile in such a way that movement is prevented without the brake lever coming into contact with the structure.

If necessary, the brake must be readjusted as described in the section "Adjusting the pit jack brake".

12.3.5 Pre-filter

Pneumatically operated pit jacks have a pre-filter at the compressed air inlet, which is necessary to protect the control unit.

To check, disassemble the compressed air coupling and remove the hexagonal threaded pin behind it. The filter can now be removed and checked for dirt and damage. If necessary, clean using compressed air or replace if damaged, see spare parts list.

12.4 Yearly inspection

Depending on the operating conditions, the lift must be inspected at intervals of no more than 12 months. In particular, safety equipment, fastenings and load-bearing components must be inspected.

This inspection must be carried out by a competent person in order to ensure safe operation until the next inspection.

The inspection and its findings must be documented.

Irrespective of these regulations, the following inspection points must be checked at least every 12 months and corrected if necessary.

12.4.1 Screw connections

All fastening screws on the pit jack and chassis must be checked and tightened using a torque wrench.

The tightening torques can be found in the corresponding section in the appendix.

12.4.2 Rollers on pit jack and FG

Rollers on the pit jack and chassis must be checked as described in section "Rollers" and replaced if necessary.

13 Servicing

Regular maintenance ensures the function and operational safety of the lift and contributes to its value retention.

To ensure the safe operation and function of the lift, maintenance must be carried out at the latest after the intervals specified in the maintenance schedule.

Maintenance work may only be carried out by specially trained and authorized personnel. Such specialist staff include authorised, trained specialists employed by the manufacturer, the authorised dealers and the relevant service partners.

13.1 Safety regulations



WARNING

- All maintenance work must be carried out in an unloaded state
 - Personal protective equipment, in particular safety goggles, safety shoes and gloves, must be worn.
 - Pit jack is fully retracted, freely accessible without load and cleaned.
 - The pit jack must be disconnected from the compressed air supply or the power supply.
-

13.2 Washing / cleaning / oiling

Residues of underbody coating and other uncleanliness can destroy the seals. Remove dirt from the piston rod regularly. Also pay attention to the area of the seal.

Do not use harsh cleaning agents for cleaning.

Do not use abrasive cleaning agents to clean the piston rod and seal.

After washing, oil all bare and moving parts to prevent corrosion and flash rust.

13.3 Empty stroke

The pit jack must be extended to full lifting height at least once a week and pumped through several times (3-4 pump strokes) with the drain spindle closed. As a result, it is automatically vented.

13.4 Maintenance unit

The water separator of the maintenance unit must be emptied and cleaned once a week to prevent water from entering the oil circuit.

In the course of this, the air oiler of the maintenance unit must be checked and the oil topped up if necessary.

For the air lubricator, we recommend hydraulic oil in the viscosity range according to ISO 3448 - ISO class VG 32.

13.5 Lubricate

The rollers on the suspended and rail-guided chassis are mounted on needle bearings. These must be relubricated every six months to remove any water and dirt that may have penetrated and to supply the bearings with unused lubricant. Grease nipples are fitted to the axles to supply the bearings with multi-purpose grease.

Pump in grease while turning the roller until fresh lubricant emerges. Wipe off any escaping grease with a paper towel and dispose of both together in an environmentally friendly manner.

13.6 Change hydraulic oil



WARNING

- Use personal protective equipment!
- Absorb dripping quantities immediately with an oil binding agent or absorbent cloth.
- Dispose of cloths soiled with hydraulic oil in an environmentally friendly manner.

NOTICE

- The pit jack must be unloaded, freely accessible and cleaned for maintenance.
- Replace the hydraulic oil depending on ageing, water absorption and soiling, but at the latest after six years.
- Only use hydraulic oil of the same specification for refilling.
 - MPJ 1S, MPJ 2S, MPJ 3S: HLP-D 10
 - MPJ HAE: HLP-D 22

13.6.1 MPJ 1S

NOTICE

Information on the oil specification and quantity can be found in the appendix. To ensure function and reliability, the use of alternative hydraulic oil must be checked by MAHA.

The oil filler plug is located on the top plate, see Fig.

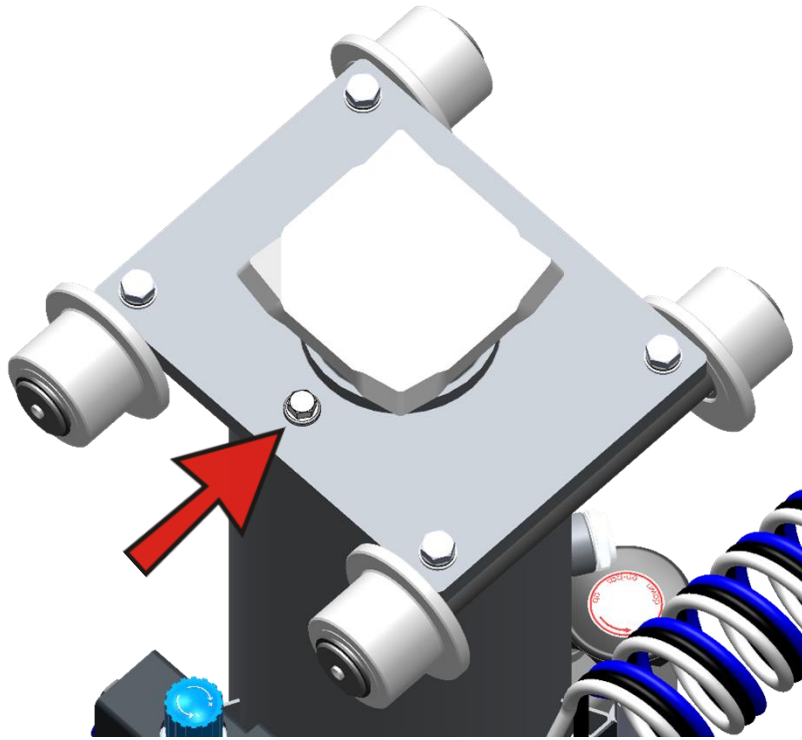

Drain oil

- Provide an oil-tight container.
- Remove the screw plugs and sealing rings, see illustration below, and drain the hydraulic oil into an oil-tight container.
- Reseal the oil drain plugs with new sealing rings.

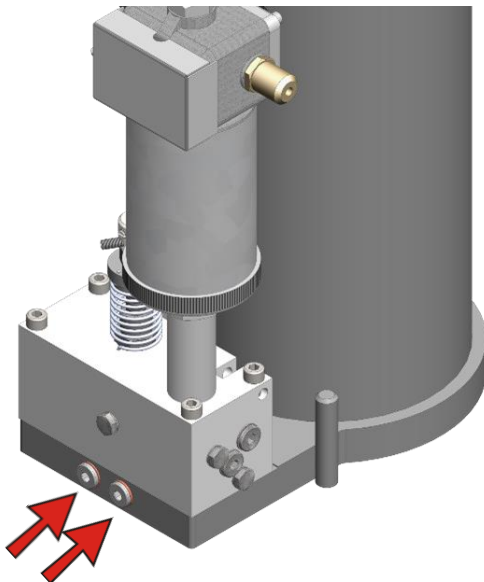

Fill with hydraulic oil

Fill in the required amount of hydraulic oil via the oil filler plug (see illustration) and close the oil filler plug again with a new sealing ring.

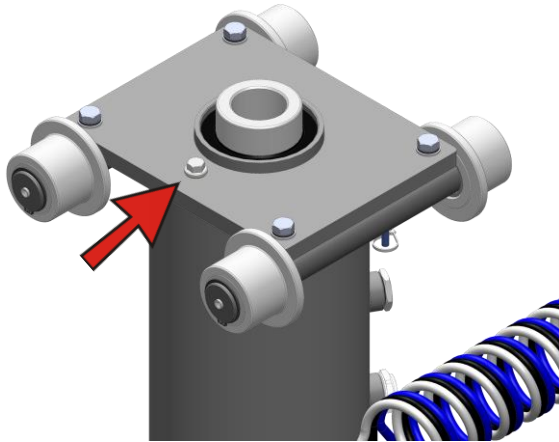

Bleeding the hydraulic system

Use personal protective equipment!

Pit jack is unloaded, freely accessible and cleaned!

The pit jack is fully retracted and load-free!

Check the oil level and top up with hydraulic oil if necessary. The target fill level of the hydraulic oil is between the two notches of the dipstick when retracted. If there is only one notch on the dipstick, this marks the maximum oil level and the lower end of the dipstick marks the minimum oil level.

Bleeding via remote control

- 1 Control the pit jack using the fast stroke (B) (remote control) until the pit jack has moved approx. 100-200 mm.
- 2 Immediately afterwards, actuate the load stroke (A) and also perform the lifting movement with the remote control for approx. 100-200 mm without pausing.
- 3 Now actuate the fast approach stroke (B) again and move the pit jack to the mechanical stop. The pit jack is now fully extended.
- 4 Actuate the load stroke (A) at the mechanical stop and wait for approx. 10-20 pump strokes of the pneumatic air motor. (Air, which is located under the piston rod, is discharged via a hydraulic valve).
- 5 Lower the jack to the starting position.
- 6 Repeat the procedure until the piston rod moves smoothly.

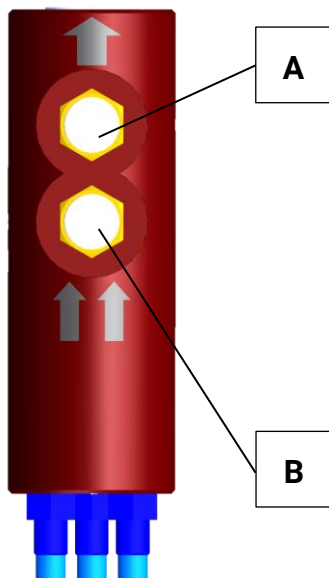

Bleeding by means of hand pumps

- 1 Pump the pit jack using the fast stroke (C) until the pit jack has moved approx. 100-200 mm.
- 2 Immediately afterwards, pump up the load stroke (B) and also perform the lifting movement without pausing for approx. 100-200 mm.
- 3 Now actuate the fast stroke (C) pump again and move the pit jack to the mechanical stop. Pit jack is now fully extended
- 4 Actuate the load stroke (B) pump at the mechanical stop and perform approx. 10-20 pump strokes.
- 5 Switch to fast stroke (C) pump and carry out approx. 10-20 pump strokes.
- 6 Lower the pit jack to the home position using the drain plug (A).
- 7 Repeat the procedure until the piston rod moves smoothly.

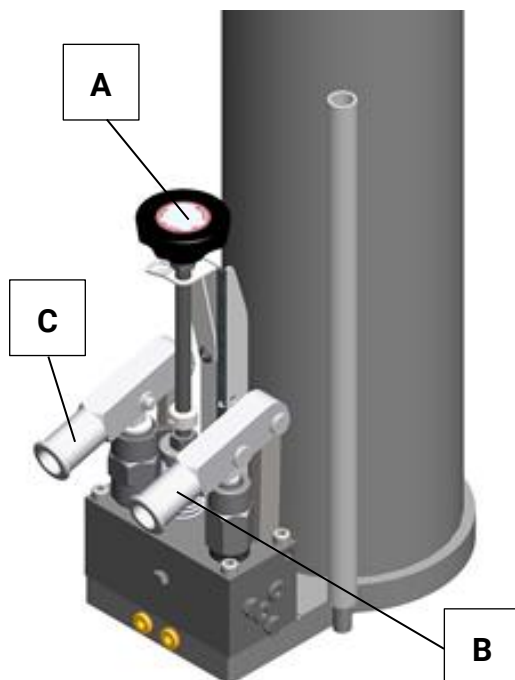

13.6.2 MPJ 2S | MPJ 3S

NOTICE

Information on the oil specification and quantity can be found in the appendix. To ensure function and reliability, the use of alternative hydraulic oil must be checked by MAHA.

Tools required

- Waste oil container 40 l
- Transparent collecting vessel 5l
- Allen key A/F 5, A/F 6
- Bleeding block, see section "Bleeding the hydraulic system MPJ 2S | 3S"

Drain oil

- Absorb dripping quantities immediately with absorbent rags.
- Bind larger quantities with oil binding agent.
- Dispose of rags or saturated binding agent properly.
- Lift the jack out of the chassis and place it safely on a raised, level surface. Disassembly in reverse order, as described in the "Installation" chapter.
- Place the collection container underneath.
- Remove the screw plugs and sealing rings and drain off the hydraulic oil (A).
- Seal the screw plugs with new sealing rings.

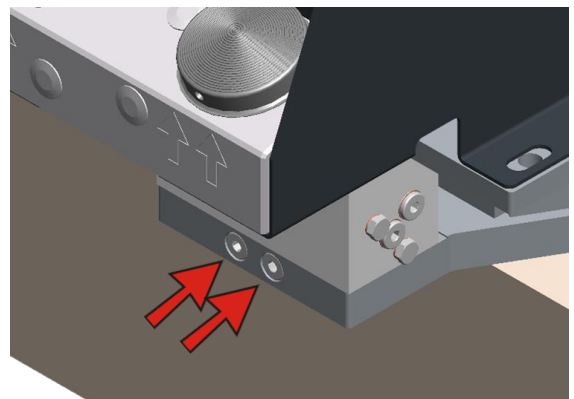
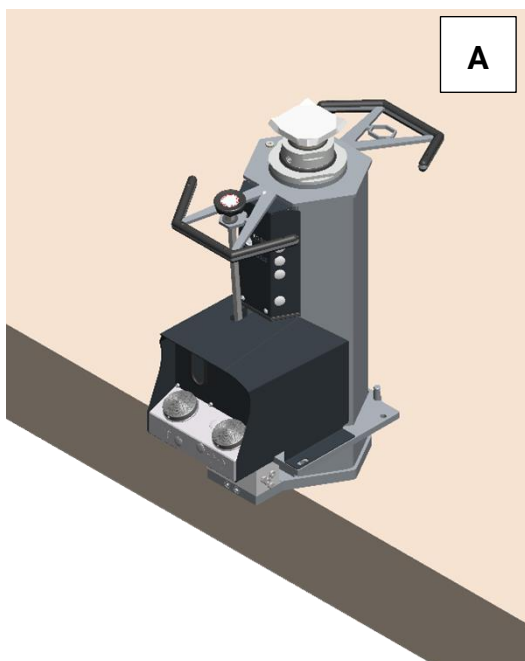

Fill with hydraulic oil

Step 1:

Oil quantities see also appendix

- 1 Remove the M14x1.5 screw plug (B).
- 2 Fill in the following partial quantities:

2S 11.5 l

3S 18.5 l

- 3 Close the oil filler opening with the screw plug.

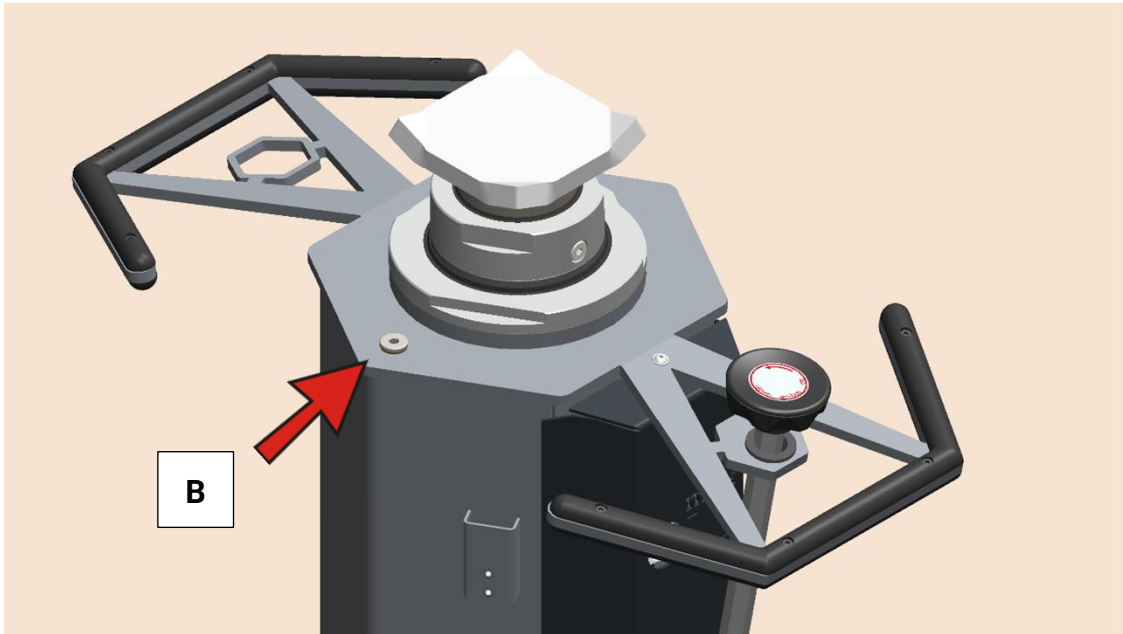

Step 2:

- 1 Place a cloth around the piston rods below the bleed screw.
- 2 Remove the screw plug including the USIT sealing ring.
- 3 Immediately afterwards, screw in the bleeder valve and tighten it hand-tight. Ensure that the bleeder valve is closed (a small amount of hydraulic oil may escape during this process).
- 4 Connect the pit jack to the compressed air network.
- 5 Actuate the **fast approach stroke** and extend to the end stop. Wait approx. 10 seconds until no more escaping air can be heard.
- 6 Disconnect the pit jack from the compressed air supply.
- 7 Remove the filler plug, top up with a second portion of hydraulic oil and screw the filler plug back in as described above.

2S 8.5 l

3S 21.5 l

- 8 Connect the bleeder valve (C) with a pneumatic hose, outer diameter 8 mm (calibrated). The recommended hose length is 1.25 m. The open end of the hose must be fed into the transparent collection container.
- 9 The bleeder valve (C) can now be unlocked and the hydraulic system can be flushed using **the load stroke** . **Load stroke** must be actuated continuously.



CAUTION

Under no circumstances should the fast approach stroke be actuated, as this would cause air to enter the hydraulic lifting system.

-
- 10 For pit jack **2S** , 4.2 liters and for pit jack **3S** , 12 liters must be discharged by actuating the load lift.
 - 11 As soon as the specified quantity has been removed, the bleeder valve is closed first and then the operation of the load stroke is stopped immediately.
 - 12 Fully retract the pit jack. Make sure that the oil sight glass is half covered when retracted. Top up with oil if necessary. (The pit jacks have an oil reserve of at least 10 % of the operating volume, see DIN EN 1494:2009 5.5.3.6)
 - 13 Remove the hose from the bleeder valve (C) and allow any residual oil in the hose to run into a container.
 - 14 Place a cloth underneath the screwed-in bleeder valve (C).
 - 15 Remove the bleeder valve (C) and screw in the screw plug immediately afterwards. Minimum installation torque of the screw plug 7.1 Nm.

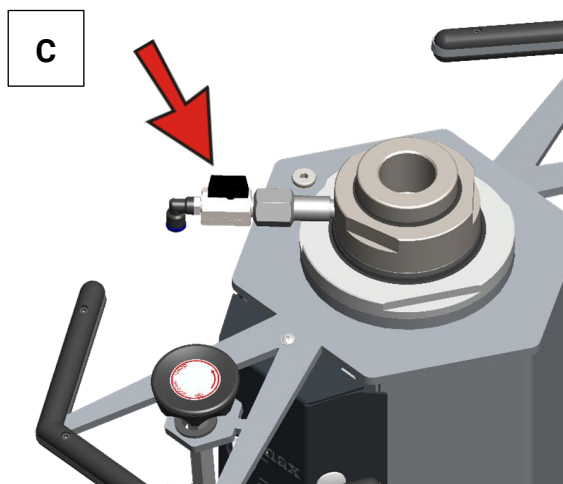

Bleeding the hydraulic system



WARNING

Use personal protective equipment!

Pit jack is unloaded, freely accessible and cleaned!

The pit jack is fully retracted and load-free!

The pit jack must be disconnected from the compressed air supply.

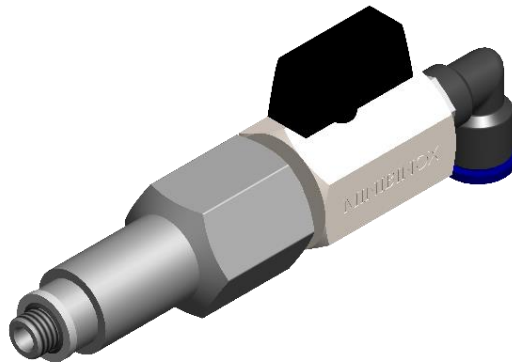

Bleeding block

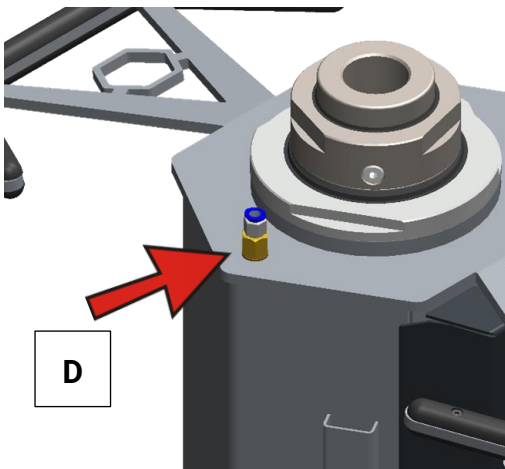
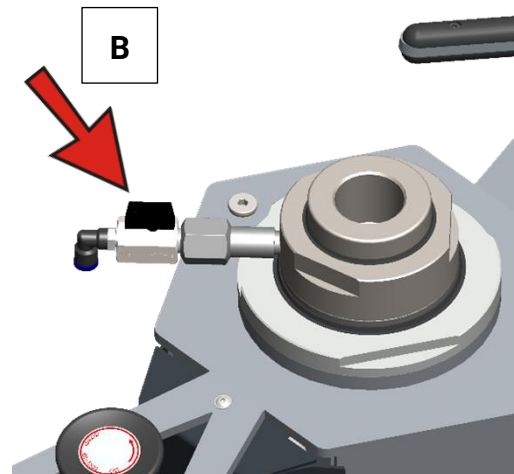
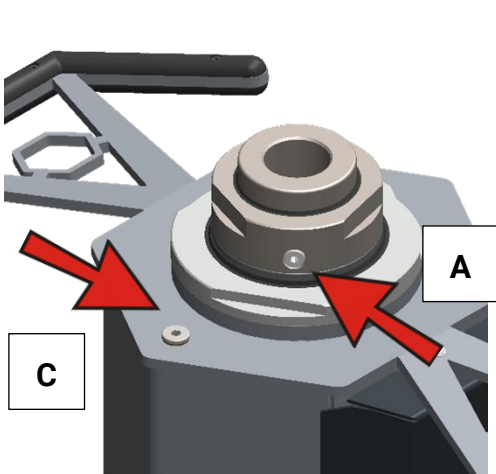

- 1 Check the oil level and top up with hydraulic oil if necessary. The target fill level of the hydraulic oil is in the center of the oil sight glass when retracted.

- 2 Check the condition of the hydraulic oil via the oil sight glass and replace if necessary (see section "Replacing the hydraulic oil").
- 3 Place a cloth around the piston rods below the G1/8" screw plug. The screw plug including the USIT sealing ring can then be removed (A). Immediately afterwards, screw in the bleeder valve (B) and tighten it hand-tight. Make sure that the bleeder valve is closed, among other things. A small amount of hydraulic oil may escape during this process.
- 4 Remove the oil filler plug (C).
- 5 Then screw in the threaded sleeve (M14x1.5a x G 1/4i) and a straight plug connection (R ¼ x Ø8 mm). Tighten hand-tight with socket wrench attachment A/F 14 (D).
- 6 The bleeder valve must now be connected using a pneumatic hose with an outer diameter of 8 mm (calibrated). The recommended hose length is 1.25 m. A transparent hose must be used to assess the hydraulic oil.
- 7 Check again that the bleeder valve is closed.
- 8 Connect the pit jack to the compressed air network. Actuate the fast stroke and extend to the end stop. Wait approx. 10 seconds until the pneumatic overpressure has been released (acoustic test).
- 9 The bleeder valve can now be unlocked and the hydraulic system can be bled and flushed using the load stroke. Load stroke must be actuated continuously.



CAUTION

Under no circumstances should the fast approach stroke be actuated, as this would cause air to enter the hydraulic lifting system.

-
- 1 Bleed the air until no air bubbles can be seen in the hydraulic oil (transparent hose). The hydraulic oil should run back into the tank clear and without air bubbles. The recommended Bleeding time is at least 1 minute.
 - 11 If the hydraulic oil is now free of air bubbles, the bleeder valve is closed first and then the load stroke is stopped immediately.
 - 12 Fully retract the pit jack and then extend it again. Repeat the bleeding process.
 - 13 Fully retract the pit jack.
 - 14 Remove the hose from the bleeder valve and allow any residual oil in the hose to run back. Remove the straight screw-in fitting and screw in the screw plug.
 - 15 Place a cloth underneath the screwed-in bleeder valve.
 - 16 Remove the bleeder valve and screw in the screw plug immediately afterwards. Minimum installation torque of the screw plug 7.1 Nm.

13.6.3 MPJ HAE

NOTICE

Information on the oil specification and quantity can be found in the appendix. To ensure function and reliability, the use of alternative hydraulic oil must be checked by MAHA.

Drain oil

- The pit jack must be disconnected from the power supply.
- Provide a 20 l collection container for used oil.
- Open the oil drain plugs and drain the old oil into the collection container (A).
- Reseal the oil drain plugs with new seals.

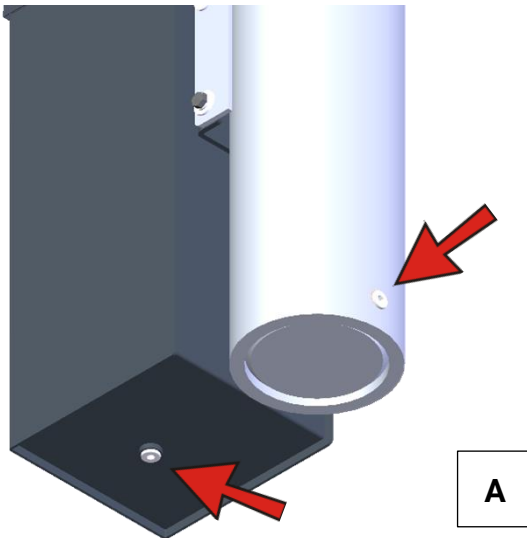

Fill with hydraulic oil

- 1 Remove the sheet metal cover (B) and open the oil filler cap underneath.

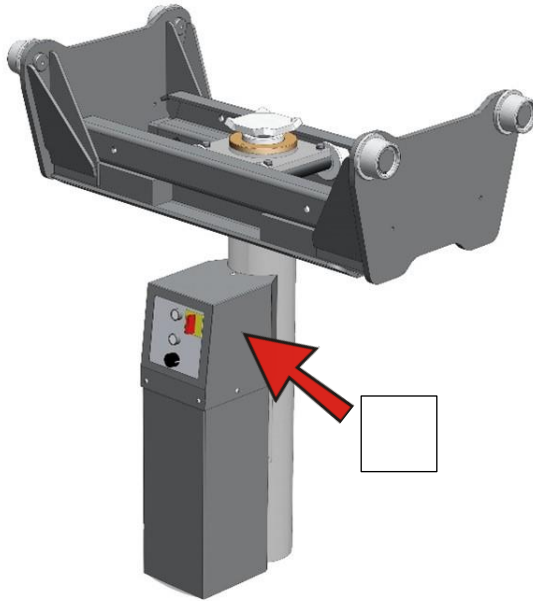

- 2 Fill in the first partial quantity of 10 liters of hydraulic oil and move the pit jack to 2/3 of the lifting height.
- 3 Then fill in another 5 liters of hydraulic oil.
- 4 Close the oil cap and fit the sheet metal cover.

Bleeding the hydraulic system

- 1 Move the pit jack to the end stop and carefully open the screw (C) by pressing the lift command.
- 2 The screw (C) must be opened gradually and in maximum quarter turns until it can be heard that air/air-oil is escaping.
- 3 Any air present is fed back into the tank via the pipe (blue). Close the screw (C) again and release the lift button.

Important: while the screw (C) is open, the lift button must be pressed continuously.

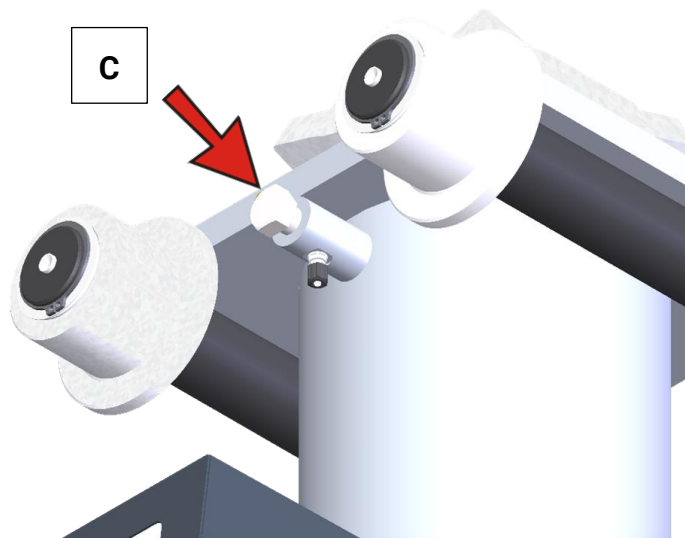

4 Fully retract the pit jack and then extend it again. If the piston rod moves smoothly, the bleeding is complete.

5 A slight jerking (in the millimeter range) of the piston rod can be quite normal; this may occur when the seal set is replaced and normalizes within a few operating hours.

6 If the piston rod still does not move smoothly, bleed the air as often as necessary until smooth movement is achieved.



CAUTION

The bleeding process will cause the hydraulic oil to heat up. The surface temperature of the oil tank should not exceed 55°C. Allow the hydraulic oil to cool down and continue the bleeding process at a later time.

Observe the tightening torque of the screw (C) of 85 Nm!

13.7 Setting the pit jack brake

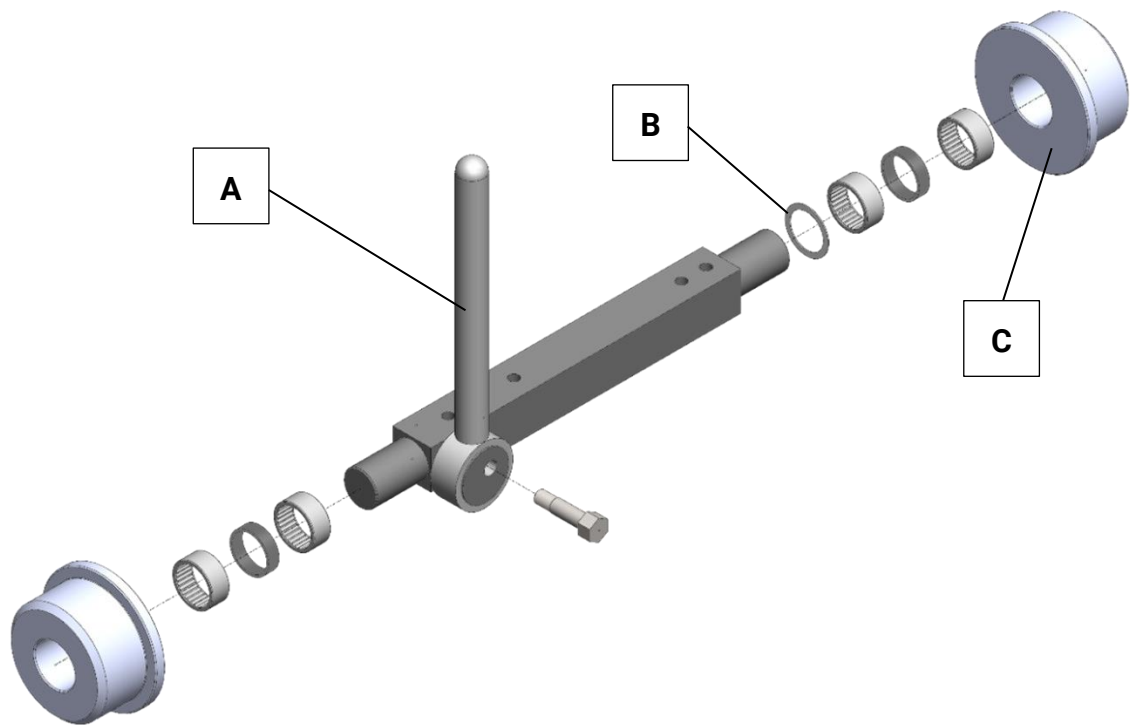

A Lifting brake

B Shim

C Pit jack roller

The brake is used to fix the pit jack in the chassis.

The brake lever moves an eccentric. This in turn presses on the back of one of the four rollers. This causes the two rollers of this jack axle to spread into the chassis, braking the rollers of one jack axle and preventing the jack from moving in the chassis.

The effectiveness of the lifting brake is based on the limited displacement and the defined play between the lifting rollers and their guide in the chassis.

The clearance of the lifting rollers in the chassis must be set to min. 1 mm and max. 2 mm.

The shims may only be added on the opposite side of the pit jack brake (on the right in the picture).

On the second, unbraked, jack axle, the same number and thickness of shims must be placed on the same side to prevent the jack from skewing and jamming in the chassis.

Shim washers may already be present on delivery in order to ensure the effectiveness of the brake despite production-related tolerances.

If the lever is overstressed or the eccentric is worn, it may be necessary to restore the functional clearance with additional washers.

14 Repairs



WARNING

Service and repair work on the lift may only be carried out by authorised and trained specialist personnel!

The lifting system and its components were extensively tested during development and before marketing. Original spare parts correspond in quality and condition to those of a new lifting system. To ensure the operational safety and longevity of your system, we recommend the exclusive use of original spare parts.

After repairing or replacing load-bearing parts, we recommend carrying out a functional test with a load to check the correct assembly, the movement of all parts and any settling behavior.

For these tests, we recommend using a typical vehicle to be lifted with a tare weight of approx. 75% of the nominal load.

The nominal load specified on the rating plate must never be exceeded!

Overload tests to check the strength of the load-bearing parts were carried out as part of the conformity assessment procedure. The load-bearing capacity of the system and the relevant components was verified up to 1.5 times the nominal load.

Exceeding the rated load can lead to pre-damage to components and thus to increased wear and premature failure.

14.1 Seal kit replacement MPJ 1S

- 1 Personal protective equipment must be worn!
- 2 Pit jack is unloaded, freely accessible and cleaned!
- 3 Fully extend the jack without load!

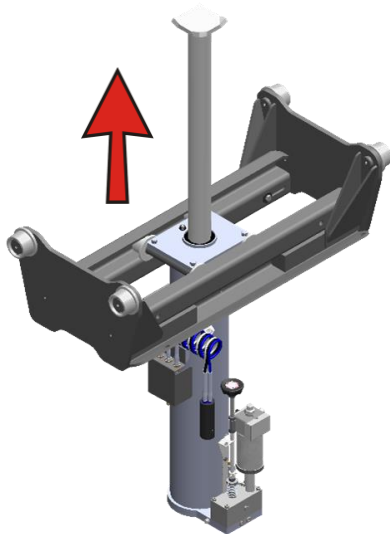

- 4 Disconnect the pit jack from the compressed air supply.

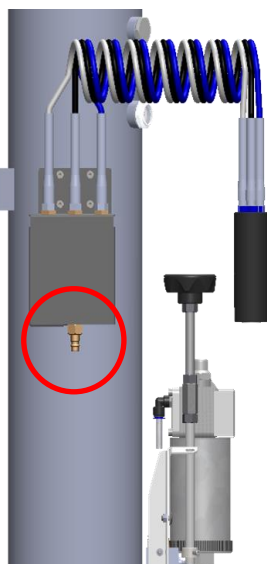

- 5 Open the drain spindle slightly until the piston rod can be turned by hand. (the piston rod may drop slightly).

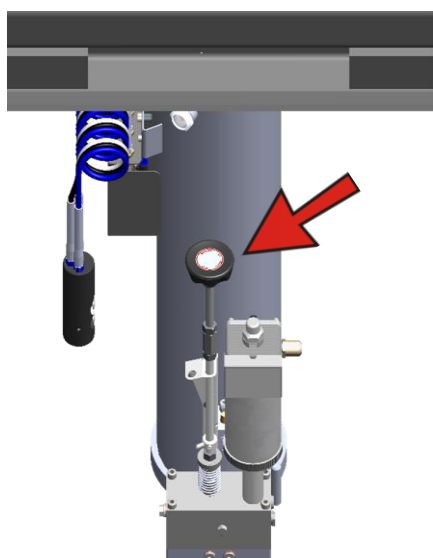

- 6 Disconnect the pneumatic control line from the valve (valve is located behind the drain spindle and the air motor).

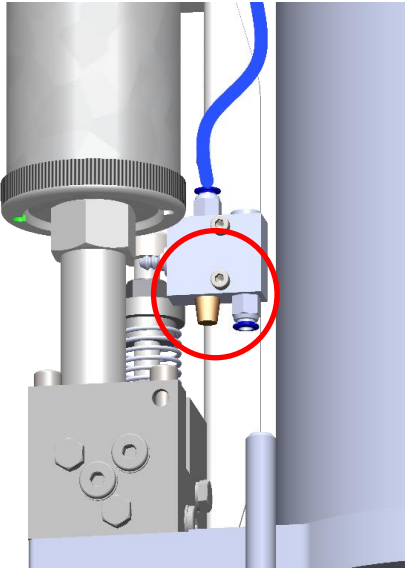

- 7 Place an oil-tight container under the hose.
- 8 Remove the wiper using a slotted screwdriver. Scraper is destroyed in the process.

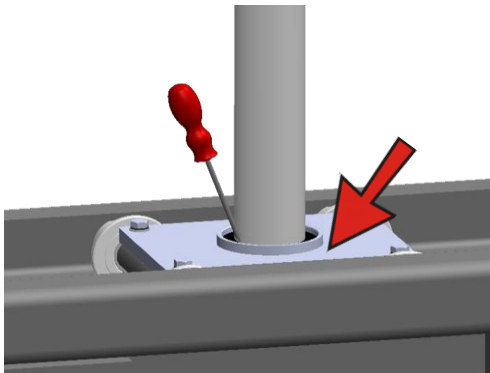

- 9 Push the scraper upwards.

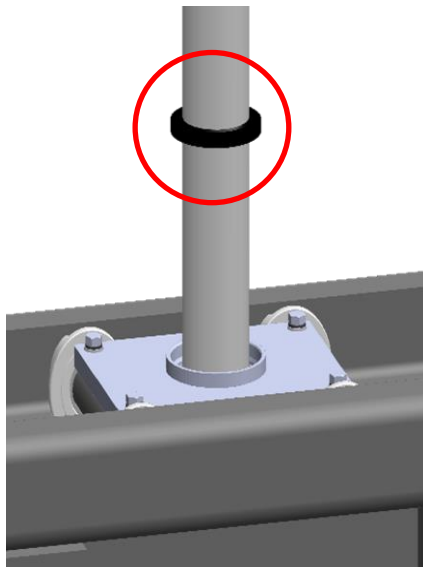

- 10 The **retaining ring** can then be removed with pliers.

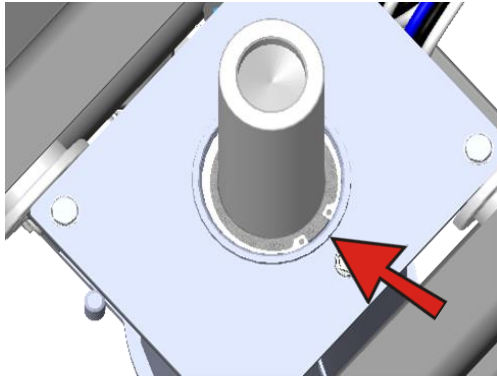

- 11 Remove the pneumatic control line on the pit jack, which is located directly below the head plate.

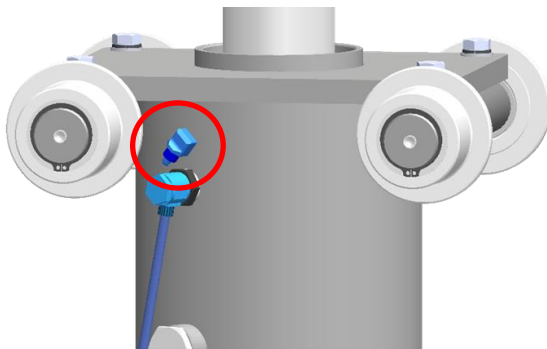

- 12 Connect the jack to the compressed air supply and actuate the load stroke!



WARNING

Danger due to incorrect operation!



- 13 Extend the piston rod using the load stroke, as shown in the following picture. Hold the piston rod firmly. Another person must be consulted for support. Pull out the piston rod with a gentle stirring motion. After dismantling the piston rod, the pit jack must be disconnected from the compressed air supply again.

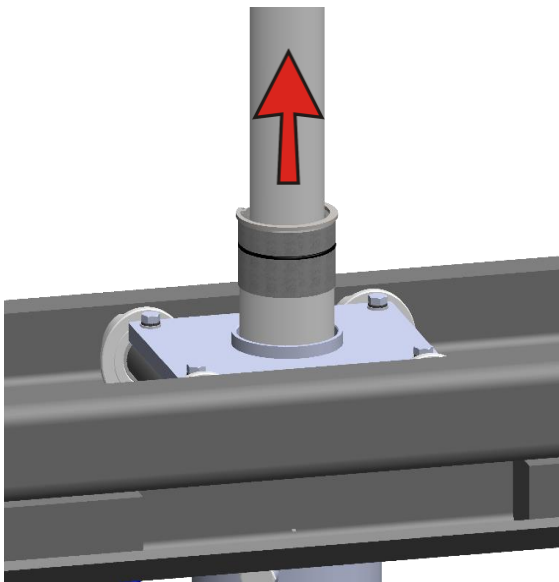

14 The seal kit must be replaced as originally installed. The structure of the sealing package with full equipment is shown here as an example.

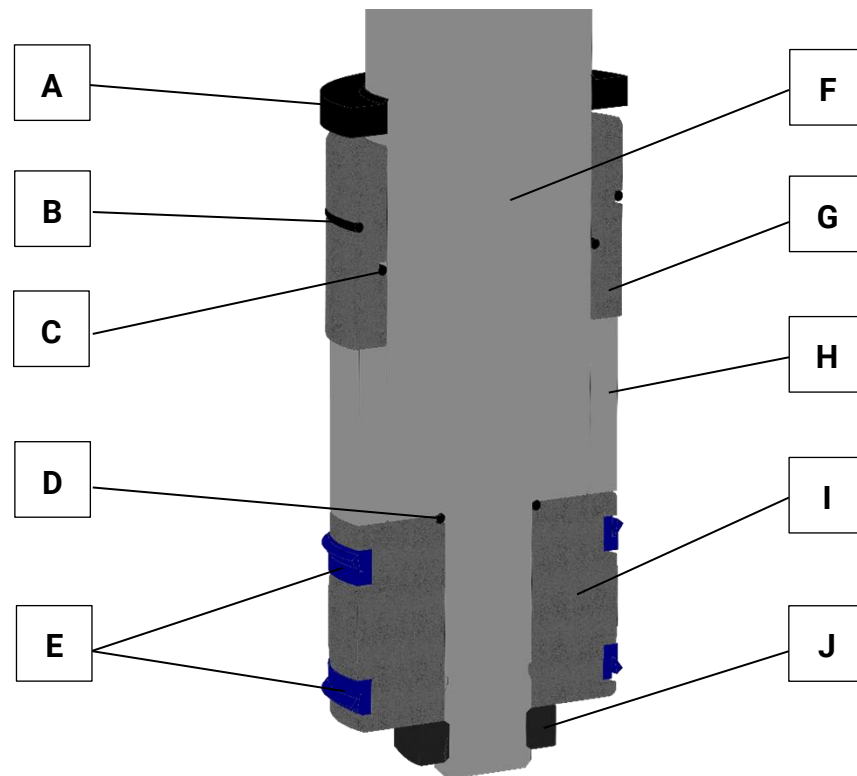

A Scraper NDA.07009510
B O-ring NDO.08603
C O-ring NDO.07003
D O-ring NDO.03003
E Slotted rings NDN.08009010

F Piston rod
G Guide bushing
H Spacer bushing
I Piston
J Hexagon nut A/F 46

- 15 To replace the seal kit, the hexagon nut A/F 46 must be removed (remove or install using an impact wrench). The piston, the spacer bushing and the guide bushing can then be removed. Make sure that the components are dismantled downwards.
- 16 If components (piston, piston rod, ...) need to be replaced, these can now be replaced. Before the new seals are fitted, all components must be cleaned and checked for damage.
- 17 Only fit all seals using suitable tools (without sharp edges!).
- 18 Push all components (guide bushing, spacer bushing, piston) onto the piston rod from below and secure with hexagon nut A/F 46.
- 19 Operate the drain spindle and allow the oil to run back into the pit jack.



- 20 Then check the hydraulic oil by opening the two screw plugs and collecting the hydraulic oil in a white container. Check the hydraulic oil for discoloration, dirt particles, foaming and water content.

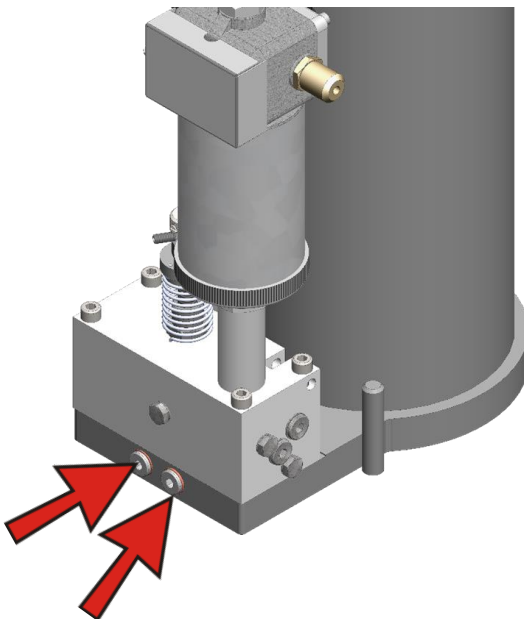

- 21 Clean the pit jack in the cylinder barrel with clean cloths and then screw in the screw plugs with new seals.

- 22 The piston rod with the hydraulic components can then be carefully reinserted into the pit jack. Make sure that the piston rod is inserted vertically into the pit jack.



- 23 As soon as the seals in the cylinder tube are tight, the lowering spindle of the pit jack must be actuated so that the piston rod in the pit jack can be lowered. Lower the piston rod to approx. half the lifting height.

- 24 Then refit the circlip.

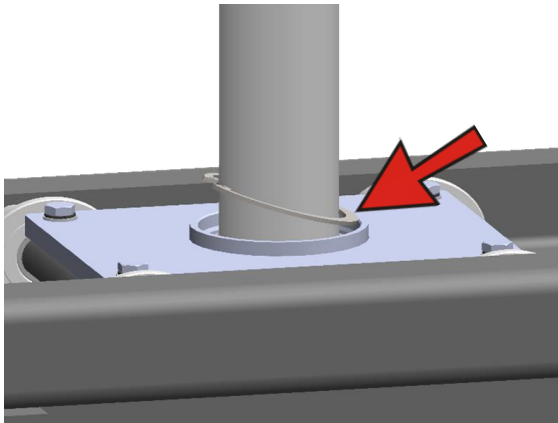

- 25 The scraper can then be refitted.

- 26 Refit all pneumatic control lines that were previously removed.

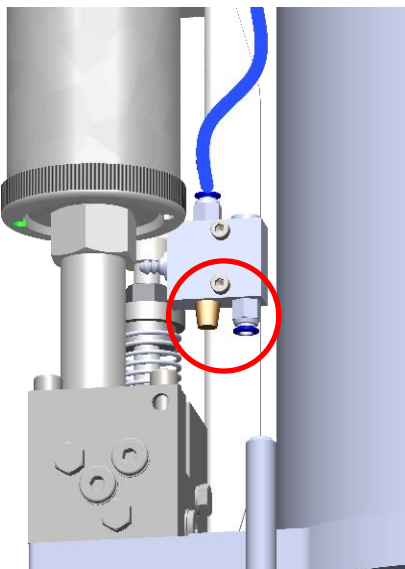

26

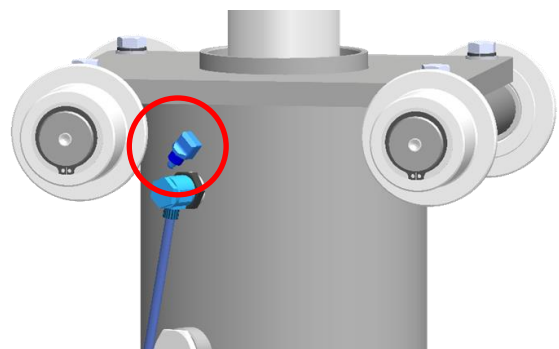

- 27 Bleed the pit jack, see chapter "Bleeding the hydraulic system".

14.2 Seal kit replacement MPJ 2S | 3S

14.2.1 Tools required

Special tools (see table) are required to dismantle the MPJ 2S and MPJ 3S pit jack.

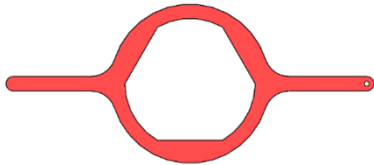

Mounting wrench for guide bushing level 3
Material number: 1283817



Mounting wrench for guide bushing stage 2
Material number: 1283278



Mounting wrench for guide bushing stage 1
Material number: 1283279



Threaded mandrel for telescopic stage 2
Material number: 1281312



Threaded mandrel for telescopic stage 3
Material number: 1281309

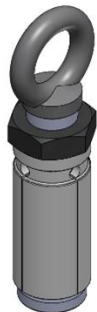

Assembly aid:
Mandrel for piston rod Material number:
1280356

- Hexagon wrench A/F 3, A/F 5, A/F 6, A/F 8
- Open-end wrench A/F 17, A/F 27, A/F 46
- Soft-face mallet, tubular steel \varnothing 15-25, approx. 500 mm long
- Screwdriver
- Circlip pliers angled

14.2.2 Overview of components for seal kit

Telescopic stage	Description	Dimensions
Stage 1 for 2S/3S	Scraper	80x88x7
	Rod seal	80x90x11
	Guide tape	80x85x25
	O-ring	Ø100x2
Stage 2 for 2S/3S	Scraper	115x127x10
	Rod seal	115x125x13
	Guide tape	115x120x25
	O-ring	Ø150x3
	Piston seal	140x125x10
Level 3 for 3S	Scraper	170x182x10
	Rod seal	170x190x16
	Guide tape	170x175x25
	O-ring	Ø230x3
	Piston seal	220x200x14

Drain the hydraulic oil (see sections "Replacing the hydraulic oil" to "Replacing the hydraulic unit").

14.2.3 Work sequence for changing seal kit, 2S | 3S pit jacks

Work steps Section 1:

- 1 Fit the installation wrench and fit the mandrel for the piston rod.

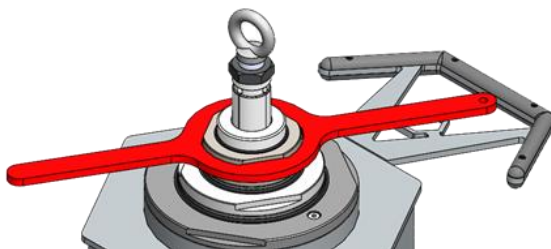

- 2 Using a lifting device, pull the piston stand upwards on the eyebolt with a slight pull (approx. 20 mm). Lifting the jack off the ground should be avoided.
- 3 Then remove the upper screw plug.

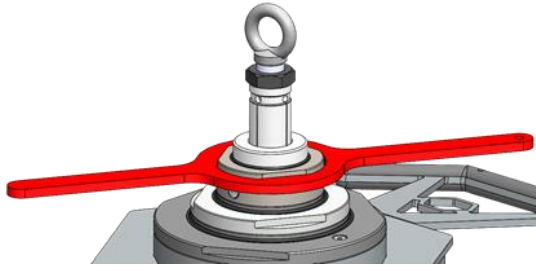

- 4 Pull the piston rod up a further 200 mm. The guide bush can then be unscrewed using the installation wrench. Loosen the guide bush by tapping lightly (with a rubber mallet) on the installation wrench.
- 5 Completely pull out the piston rod including piston and guide bushing and carefully place on a clean surface. Pit jack the hydraulic oil out of the opening.

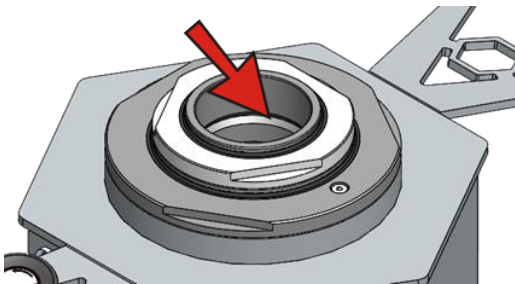

- 6 The guide bush can be pulled off upwards.



- 7 Loosen the piston using an impact wrench, nut A/F 46 and cylinder head bolts with A/F 10.



- 8 Fit a new set of seals to the cleaned guide bush. To keep the O-ring in position, we recommend applying multi-purpose grease to the groove for the O-ring. Generously coat the area inside the guide bush with hydraulic oil and push it onto the piston rod from below. Then refit the piston including

the four cylinder screws (minimum assembly torque 108 Nm) and M30x1.5 nut using an impact wrench.

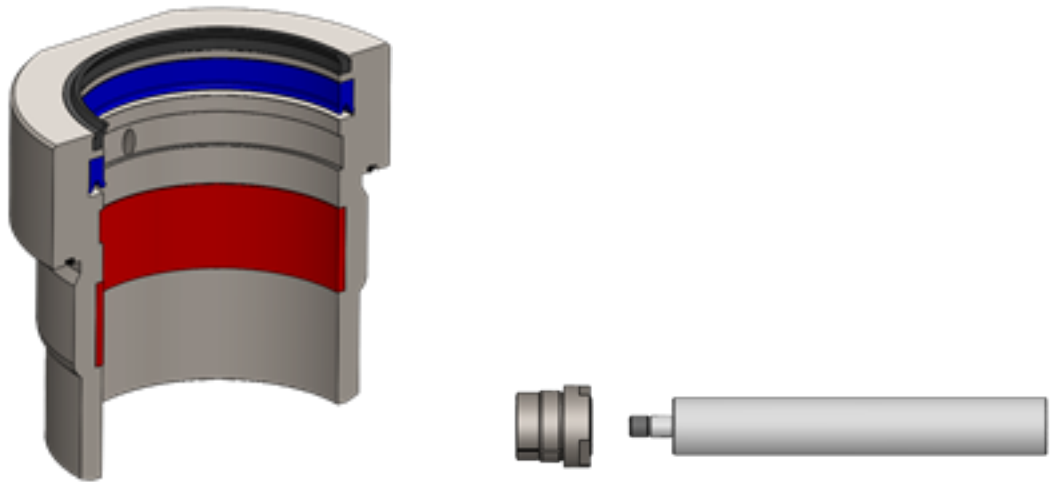

Work steps Section 2:

- 1 Fit the installation wrench and screw in the threaded mandrel.

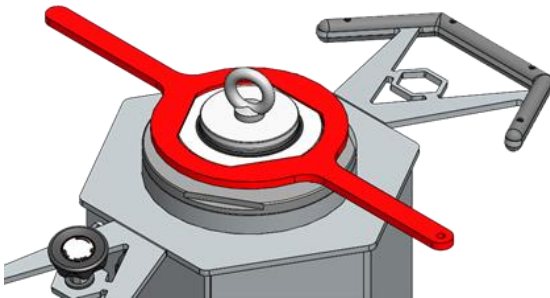

- 2 Using a lifting device, pull the cylinder tube upwards on the eyebolt with a slight pull (approx. 10 mm). Lifting the jack off the ground should be avoided.
- 3 Then remove the screw plug in the lower guide bushing. Only with MPJ 16.5/1200 3S!

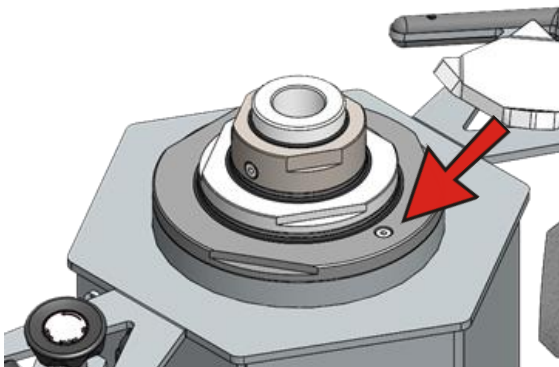

- 4 Pull the piston rod up a further 200 mm. The guide bush can then be unscrewed using the installation wrench. Loosen the guide bush by tapping lightly (with a rubber mallet) on the installation wrench.
- 5 Completely pull out the piston rod including piston and guide bushing and carefully place on a clean surface. Pit jack the hydraulic oil out of the opening.

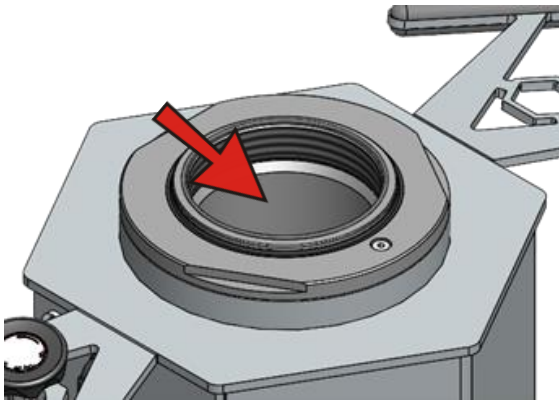

- 6 The guide bush can be pulled off upwards after the threaded mandrel has been removed.



- 7 To remove the piston, first remove the grub screw. The piston can then be unscrewed. If this does not come loose, there are two M8 threads in the piston crown for attaching a disassembly aid.



- 8 Fit a new set of seals to the cleaned guide bush and piston. To keep the O-ring in position, we recommend applying multi-purpose grease to the groove for the O-ring.

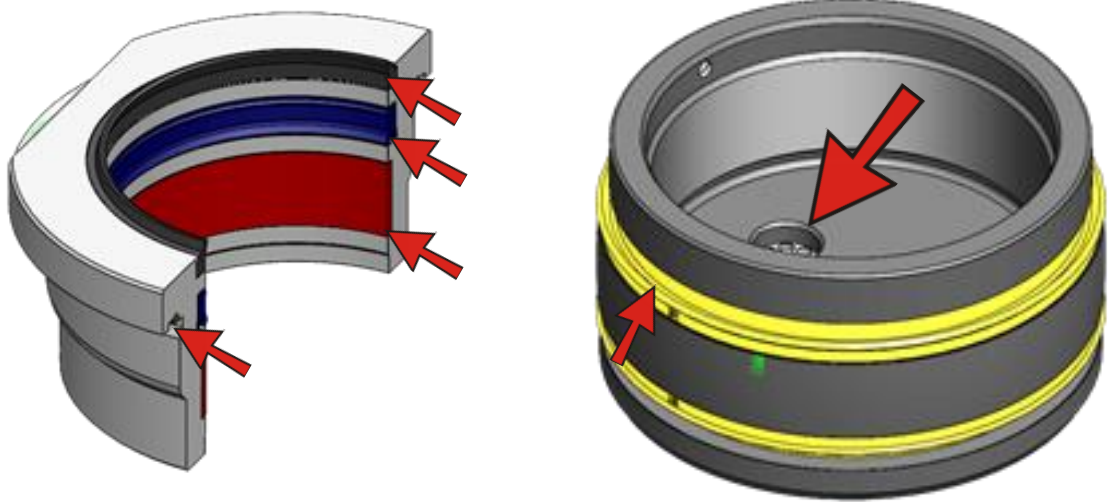

NOTICE

In the illustration on the right, a non-return valve can be seen inside the piston, see large arrow. Check for damage and contamination.

- 9 Generously coat the area inside the guide bush with hydraulic oil and push the guide bush onto the cylinder barrel from below. Then tighten the piston hand-tight and secure with a grub screw. If present, ensure that the two M8 LFK screws are screwed back into the cylinder base (only required for MPJ 16.5/1200 3S).



Work steps Section 3:

- 1 Fit the installation wrench and screw in the threaded mandrel.

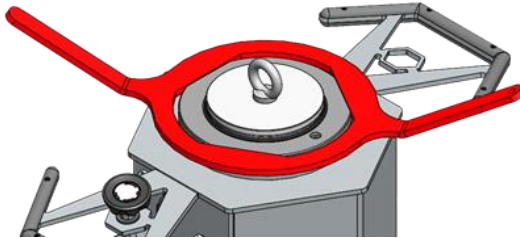

- 2 Using a lifting device, pull the cylinder tube upwards on the eyebolt with a slight pull (approx. 200 mm). Lifting the jack off the ground should be avoided.
- 3 The guide bush can then be unscrewed using the installation wrench. Loosen the guide bush by tapping lightly (with a rubber mallet) on the installation wrench.
- 4 Pull out the piston rod including piston and guide bushing completely and carefully place on a clean surface.
- 5 The guide bush can be pulled off upwards after the threaded mandrel has been removed.

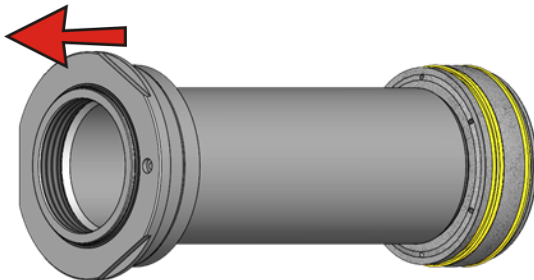

- 6 To remove the piston, first remove the grub screw. The piston can then be unscrewed. If this does not come loose, there are two M8 threads in the piston crown for attaching a disassembly aid.

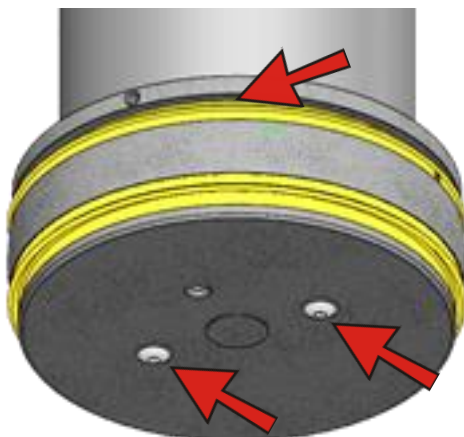

- 7 Fit a new set of seals to the cleaned guide bush and piston. To keep the O-ring in position, we recommend applying multi-purpose grease to the groove for the O-ring.

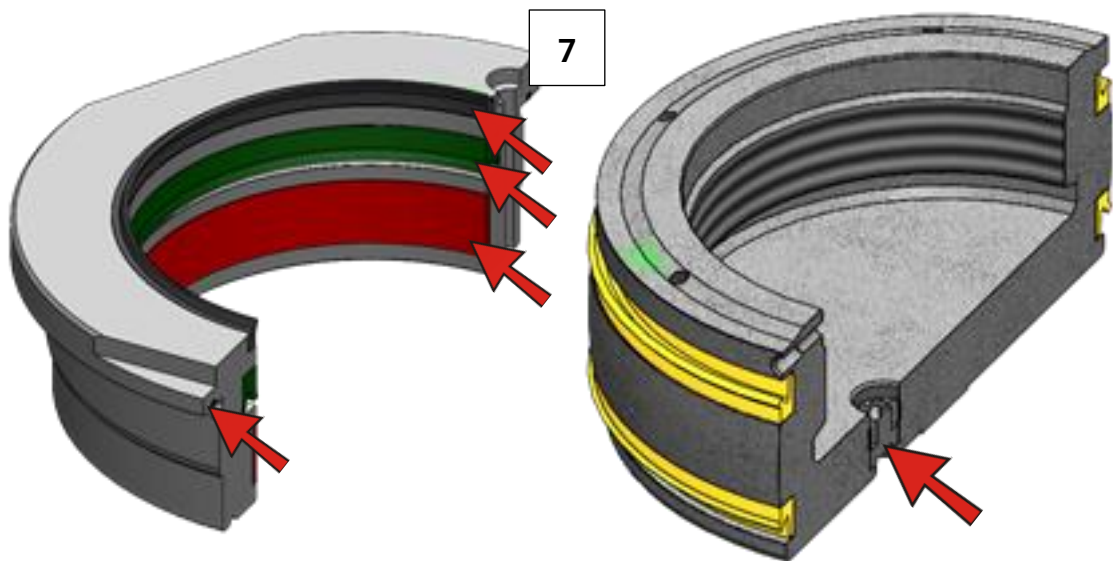

NOTICE

In the illustration on the right, a non-return valve can be seen inside the piston, see large arrow. Check for damage and contamination and replace if necessary.

- 8 Generously coat the area inside the guide bush with hydraulic oil and push the guide bush onto the cylinder barrel from below. Then tighten the piston hand-tight and secure with a grub screw. If present, ensure that the two M8 LFK screws are screwed back into the cylinder base (only required for MPJ 16.5/1200 3S).



Work step: Inserting sections 1 to 3:

Before inserting the sections, ensure that the interior is clean and that the cylinder tube is thinly coated with hydraulic oil. Never insert the sections into the pit jack by hand. Always use suitable lifting gear!

- 1 When inserting in the groove ring area (on the piston), ensure that the groove rings do not come into contact with the thread of the cylinder barrel. This also applies to all other levels!

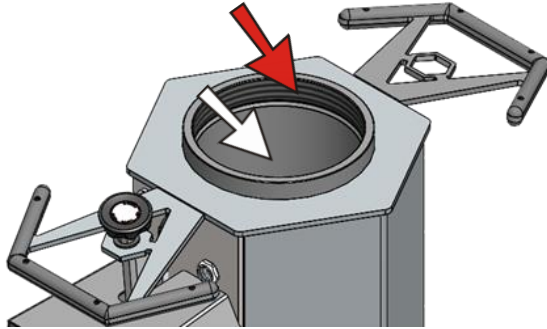

- 2 Starting with the largest section, insert all sections into the pit jack one after the other. Make sure that the screw plugs on the largest and smallest guide bushes are not fitted. (The screw plugs on the pit jack for draining the oil are open!)
- 3 When inserting the sections, ensure that the groove rings in the pistons are generously coated with hydraulic oil!

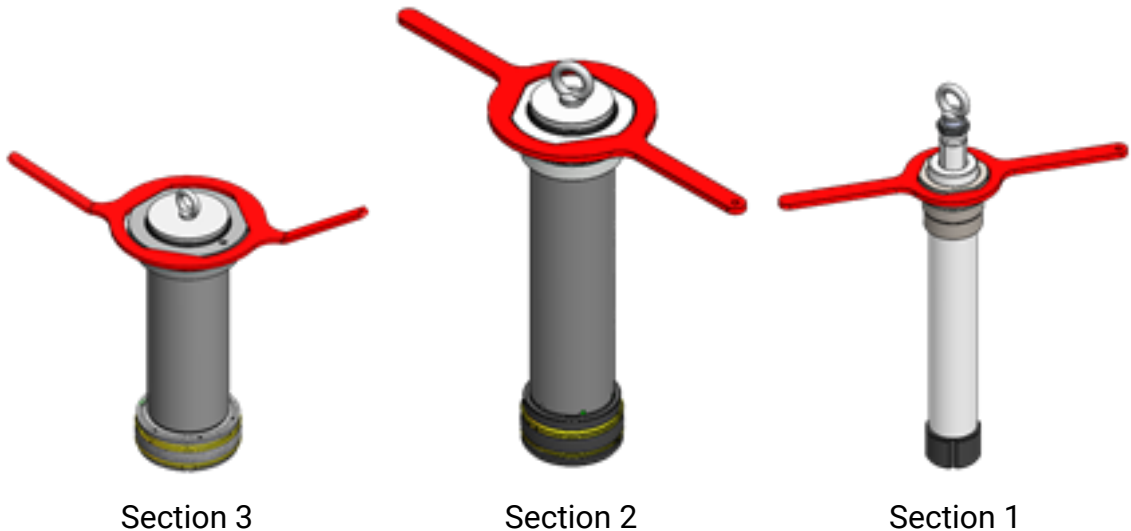

- 4 Using a lifting device, position the cylinder tube or piston rod including guide bushing, piston and installation wrench on the eyebolt above the pit jack and carefully insert it into the pit jack. To make it easier to screw in the guide bush, do not lower the sections completely into the pit jack.

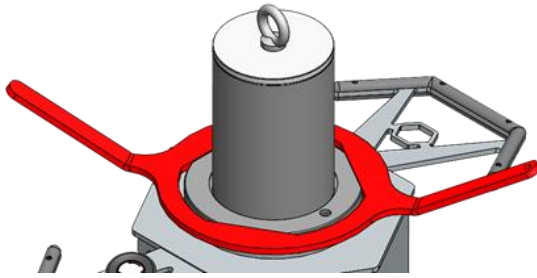

- 5 Tighten the guide bush hand-tight using the installation wrench and then fix it in place with a light tap (rubber mallet) on the installation wrench.
- 6 Lower the section completely and remove the installation wrench and threaded mandrel.
- 7 Insert the remaining sections into the pit jack as described above.
- 8 Install the screw plugs on the largest and smallest guide bush. Minimum installation torque of the screw plug 7.1 Nm. Tighten the screw plugs on the pit jack base plate. Make sure that new copper sealing rings are used!

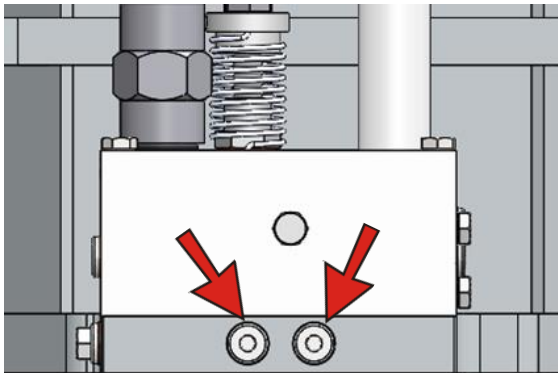

- 9 Then carry out the initial filling and bleeding of the pit jack, see sections "Filling with hydraulic oil" to "Bleeding the hydraulic system".

14.3 Replace hydraulic unit

14.3.1 Replace hydraulic unit MPJ 1S

When replacing the hydraulic unit, the hydraulic oil must also be changed at the same time.

Carry out section "Changing the hydraulic oil MPJ 1S". The hydraulic oil must be drained for further steps.

- 1 Remove the four screws on the block (hexagon head screw SW13 / cylinder head screw A/F 6). The hydraulic block can then be removed.

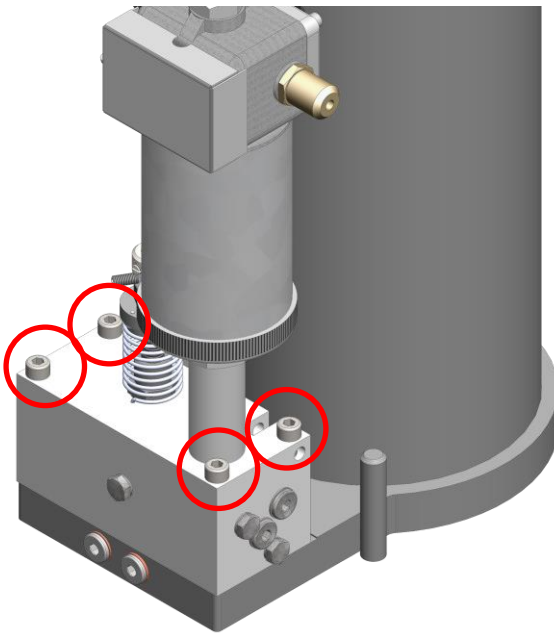

- 2 Clean the surface under the hydraulic block and fit the new hydraulic block in reverse order. Pay particular attention to the O-rings between the pit jack base plate and the hydraulic unit!

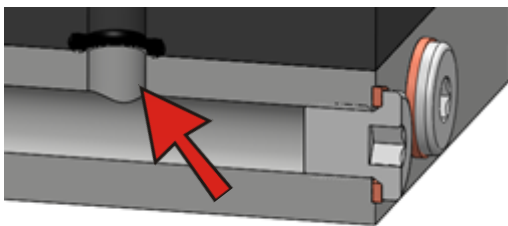

- 3 Continue in section "Changing the hydraulic oil".
- 4 Carry out section "Bleeding the hydraulic system MPJ 1S".

14.3.2 Replace hydraulic unit MPJ 2S | 3S

- 1 Only replace the hydraulic unit at the same time as an oil change. "Changing the hydraulic oil on the MPJ 2S | 3S". The hydraulic oil must be drained for the next steps.
- 2 Remove the cover (if necessary, mark the air hoses to avoid confusion).
- 3 Remove the joint of the drain spindle SW17 and then remove the four screws on the block SW13. The hydraulic block can then be removed.
- 4 Clean the surface under the hydraulic block and fit the new hydraulic block in reverse order. Pay particular attention to the O-rings between the pit jack base plate and the hydraulic unit!

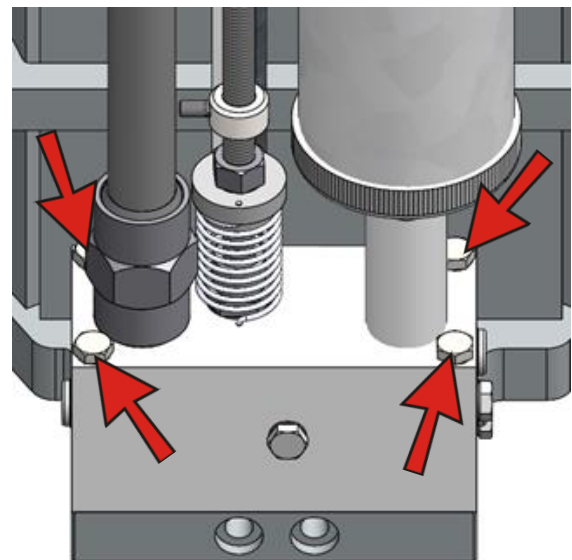
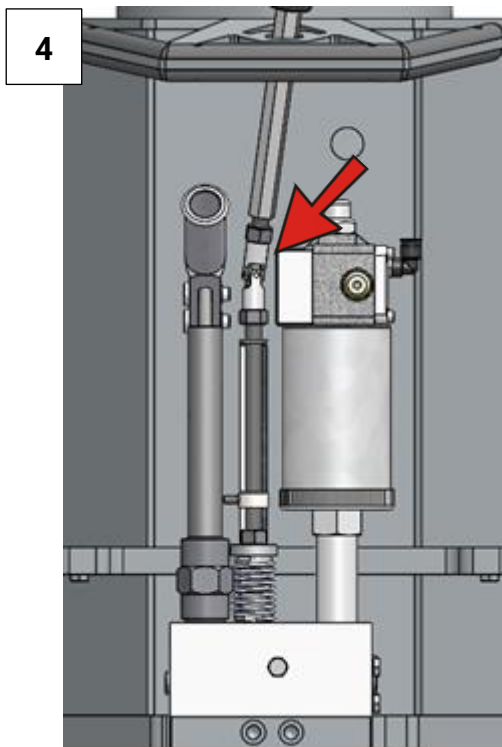

- 5 Refit the joint and cover and reconnect all air hoses.
- 6 Complete section "Changing the hydraulic oil on the MPJ 2S | 3S".
- 7 See section "Bleeding the hydraulic system MPJ 2S | 3S".

15 Annex

15.1 Tightening torques

Tightening torques for all screws without torque specification:

Thread	Strength class	Tightening torque
M5	8.8	6 Nm
M6	8.8	10 Nm
M8	8.8	25 Nm
M10	8.8	50 Nm
M12	8.8	85 Nm

15.2 Load application of the chassis

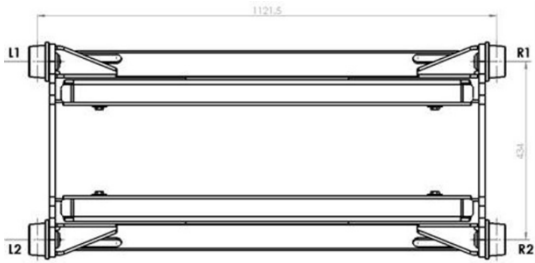
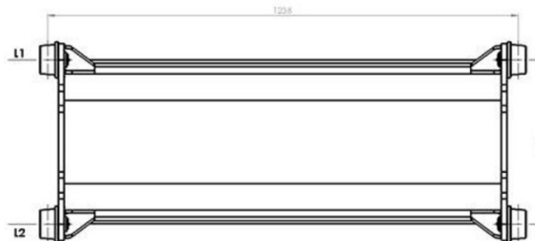
Pit jack type	F.L1 [kN]	F.L2 [kN]	F.R1 [kN]	F.R2 [kN]	Load application
*MPJ 4.0/750 1S H	26.93	26.93	5.32	5.32	FG Roll
*MPJ 16.5/750 1S H	76.05	76.05	16.16	16.16	FG Roll
					
*MPJ 20.0/750 1S H	93.04	93.04	17.56	17.56	FG Roll
					
MPJ 16.5/750 1S F	44.91	46.61	44.91	46.61	50 x 50 mm
MPJ 20.0/750 1S F	54.28	56.32	54.27	56.33	50 x 50 mm

MPJ 16.5/750 1S T	15.83	3.9	116.54	28.73	FG roll
MPJ 20.0/750 1S T	16.38	10.39	118.98	75.45	FG roll

*Worst-case assumption:

FGH 14.P-120 without release; pull-outs approx. 14 mm extended to a total width of B dimension = 1083 mm. Maximum asymmetrical force transmission via rollers into the foundation.

15.3 Hydraulic oil filling quantities



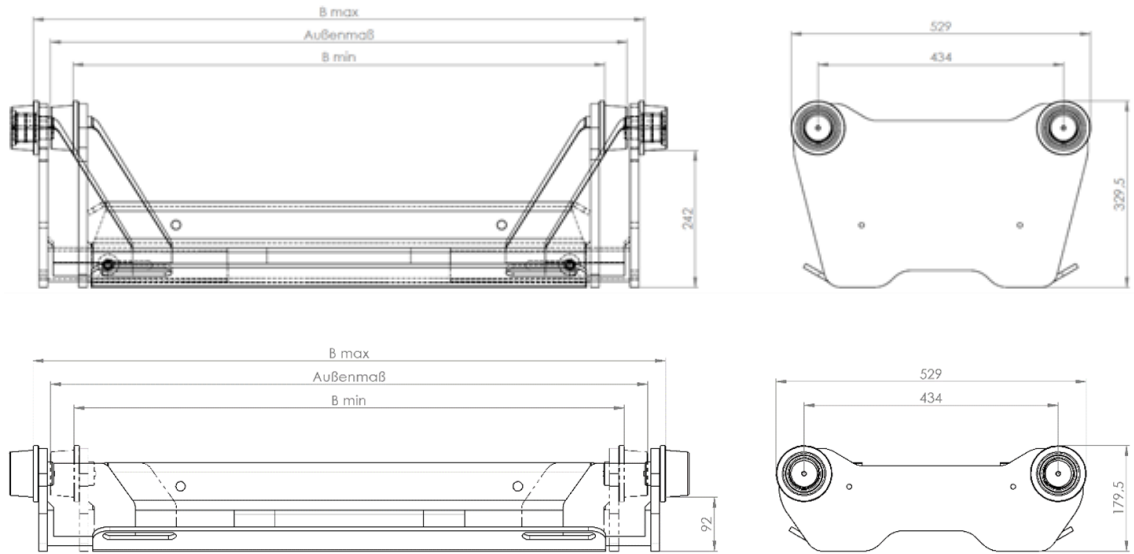

Pit jack	Hydraulic oil	Filling quantity [l]
MPJ 4/750 1S	HLP-D 10	3.3
MPJ 16.5-20/750 1S		9.5
MPJ 16.5/750 2S		15.8
MPJ 16.5/750 3S		28
MPJ 16.5/750 1S HAE	HLP-D 22	15





15.4 Dimensions adjustable chassis



B min...B max [mm]	Outer dimension (pushed together) [mm]
580 to 720	660
640 to 780	720
700 to 840	780
760 to 900	840
820 to 960	900
880 to 1020	960
940 to 1080	1020
1000 to 1140	1080
1060 to 1200	1140

15.5 Overview of chassis rollers

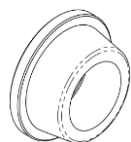
Title and image	Mat. No.	Description	Form	Inclination	Ø at the waistband	Tread	Collar Ø	Waistband width	Characteristic s/ special feature
				%	[mm]	[mm]	[mm]	[mm]	
	1267244	FG roller (conical) FG ROLLER 6-30T	conical	8	80	40	95	10	Standard
	1267245	FG roll RD 95x50	cylindrical	-	74	40	95	10	VZ
	1267253	FG roller FG ROLLER 6-30T	conical	14	80	40	95	10	I-profile with 14 % inclination
	1128378	FG roll RD 95x48	cylindrical	-	90	44.5	-	-	Difference dimension B > 10 mm; without collar
	1267257	FG roll Rd 95	conical	8	80	30	95	10	Tread 30 mm

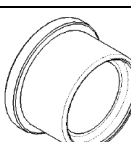
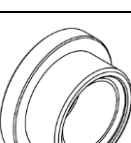
Title and image	Mat. No.	Description	Form	Inclination	Ø at the waistband	Tread	Collar Ø	Waistband width	Characteristics/ special feature
				%	[mm]	[mm]	[mm]	[mm]	
	1267255	FG roller FG ROLLER 6-30T	conical	8	80	30	95	20	Collar 20 mm
	1267254	FG roller FG ROLLER 6-30T	conical	8	80	35	95	15	Collar 15 mm
	1267252	N02.31-13	conical	8	66	30	80	10	Roller for U80 profiles
	1267249	FG roll	conical	14	80	30	95	10	I-profile with 14 % inclination
	1267248	Chassis roller RD 95x45	cylindrical	-	74	35	95	10	Tread 35 mm
	1267246	FG roller FG ROLLER 6-30T	cylindrical	-	69	40	80	10	Tread-Ø 69 mm Collar-Ø 80 mm
	1128392	FG roll RD 95x60	cylindrical	-	74	30	95	15	Tread 35 mm collar 15 mm

- 15.6 Electrical circuit diagram MPJ HAE**
- 15.7 Fluid plans**
- 15.8 Operating instructions Maintenance unit**
- 15.9 CE declarations of conformity**

See following page(s).



MAHA
Maschinenbau Haldenwang GmbH & Co. KG
 Hoyen 20
 D-87490 Haldenwang
 Germany

Equipment designation: Lifter
 Drawing number : 232.01.004573C

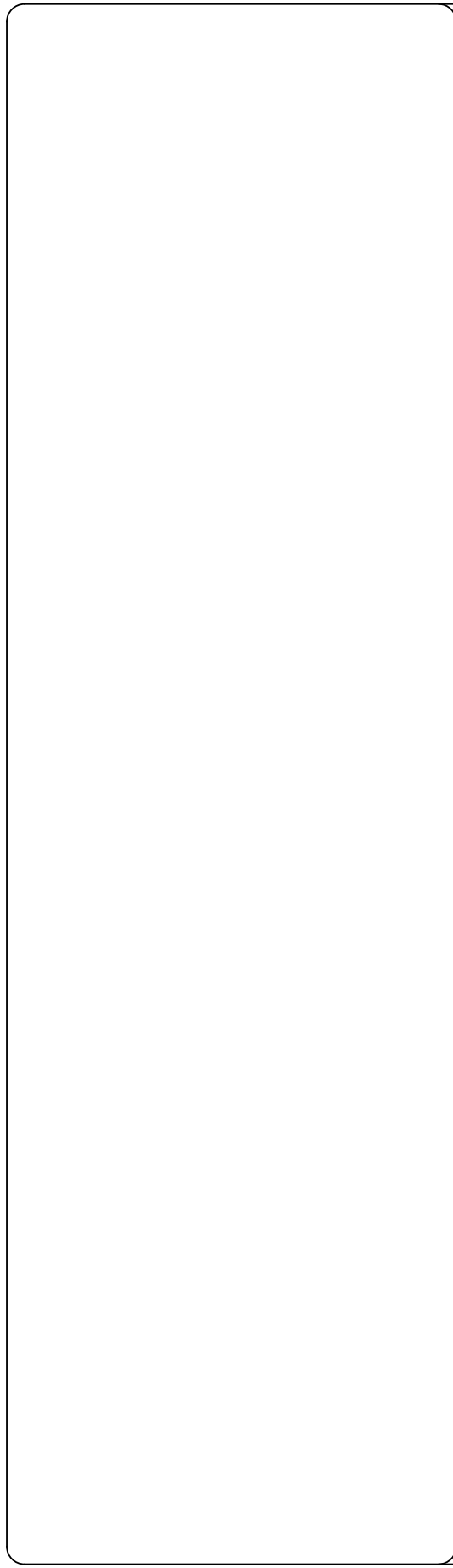

Dieser Schaltplan wurde für den maximalen Ausbau der Maschine erstellt. Optionsbedingt können Abweichungen zwischen Steuerung und Schaltplan vorhanden sein.
 This circuit diagram is intended for machines equipped with all options. Options appearing in the circuit diagram need not necessarily be present in the control unit.

Power supply : 3x400V, N, PE, 50Hz
 Fuse protection : K16A
 Created on : 07.02.2006 by: OLM
 Last modified : 21.06.2017 by: APR

Serial Number



Information to the electrical diagram

- All wiring are conceived for a control cabinet interior temperature of 45°C (113°F)

- NOTE!

All operational funds attached before the main switch must be wired with the warning color orange!

Legend of the color of conductor

- BK = Schwarz / Black / Noir / Nero
- BN = Braun / Brown / Maron / Marone
- RD = Rot / Red / Rouge / Rosso
- OG = Orange / Orange / Orange / Arancia
- YE = Gelb / Yellow / Jaune / Giallo
- GN = Grün / Green / Vert / Verde
- BU = Blau / Blue / Bleu / Blu
- VT = Violet / Violet / Violet / Viola
- GY = Grau / Grey / Gris / Grigio
- WH = Weiss / White / Blanc / Bianco
- PK = Rosa / Pink / Rose / Rosa

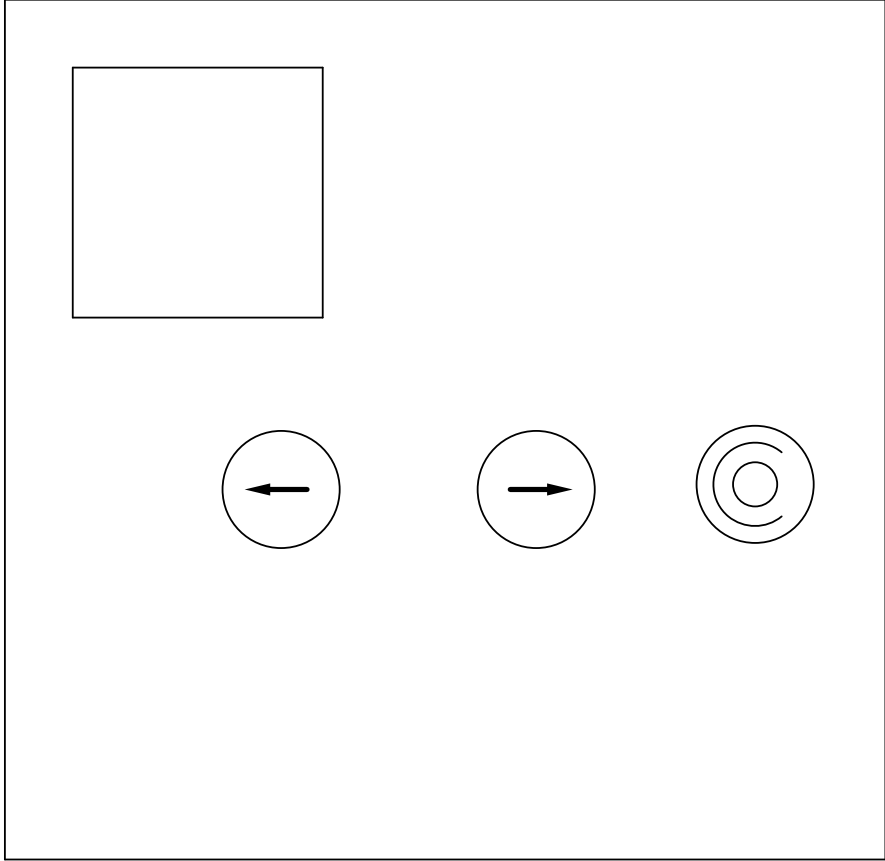
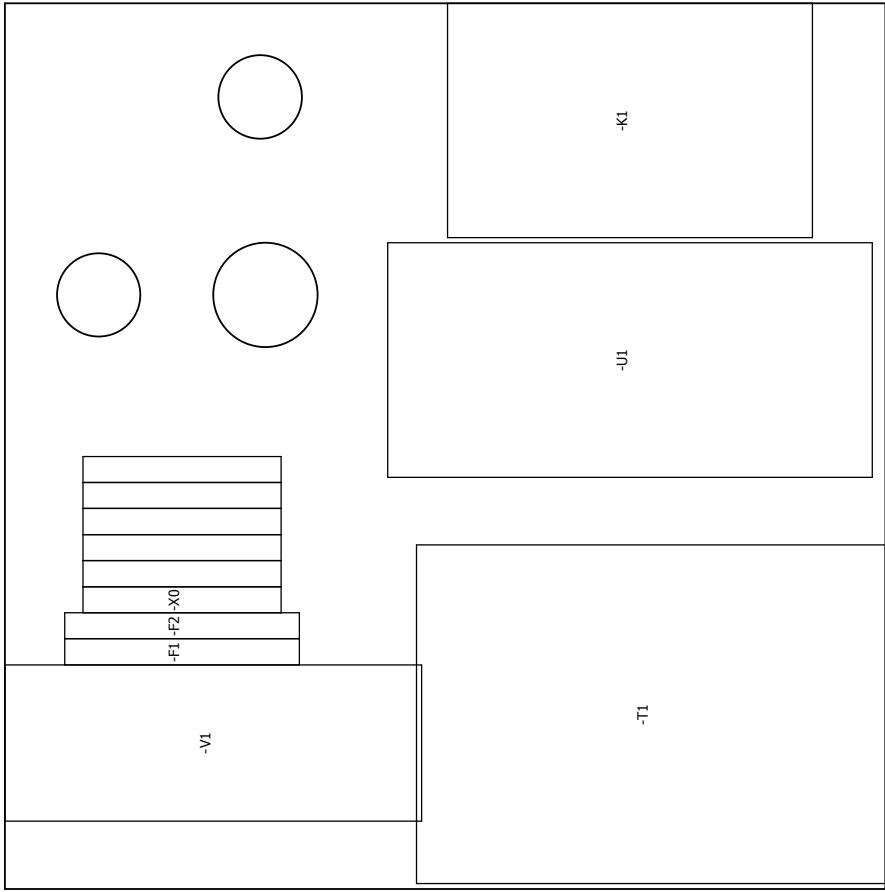

0	1	2	3	4	5	6	7	8	9
---	---	---	---	---	---	---	---	---	---

overview: Lifter

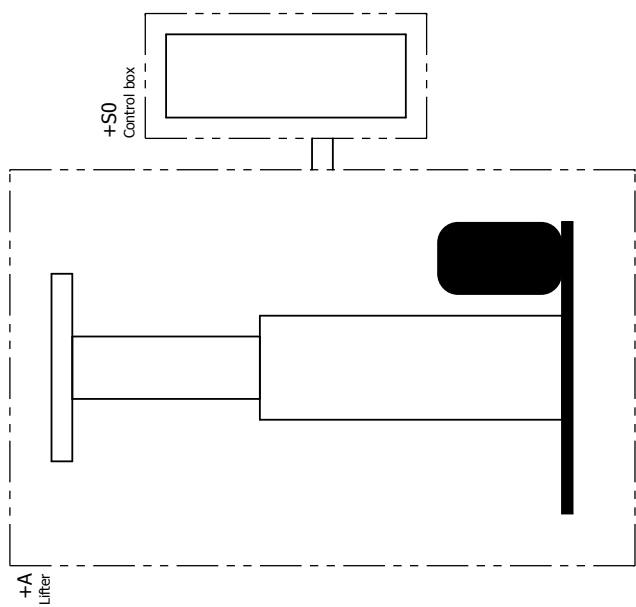

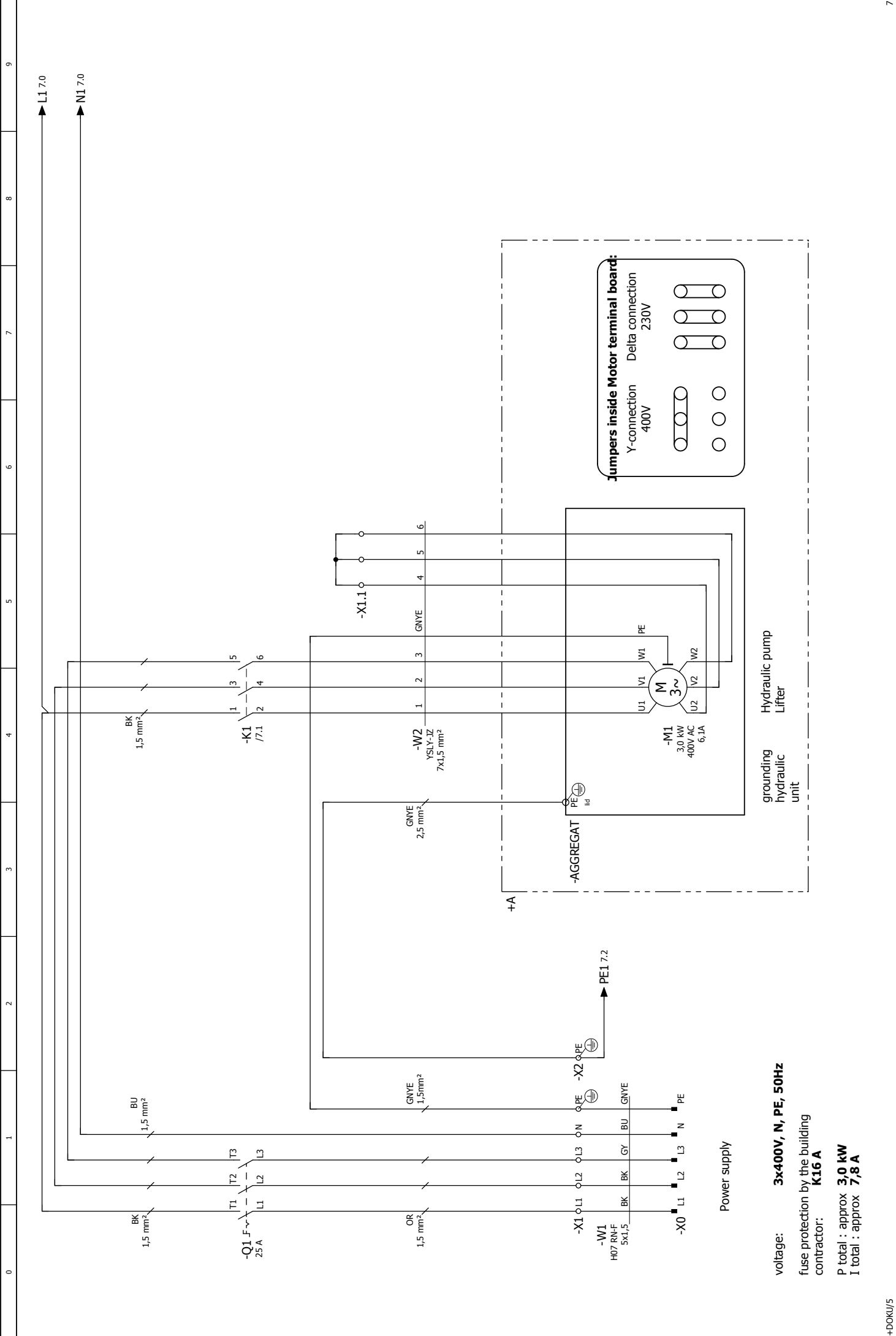

voltage: **3x400V, N, PE, 50Hz**
 fuse protection by the building contractor: **K16 A**
 P total : approx **3,0 kW**
 I total : approx **7,8 A**

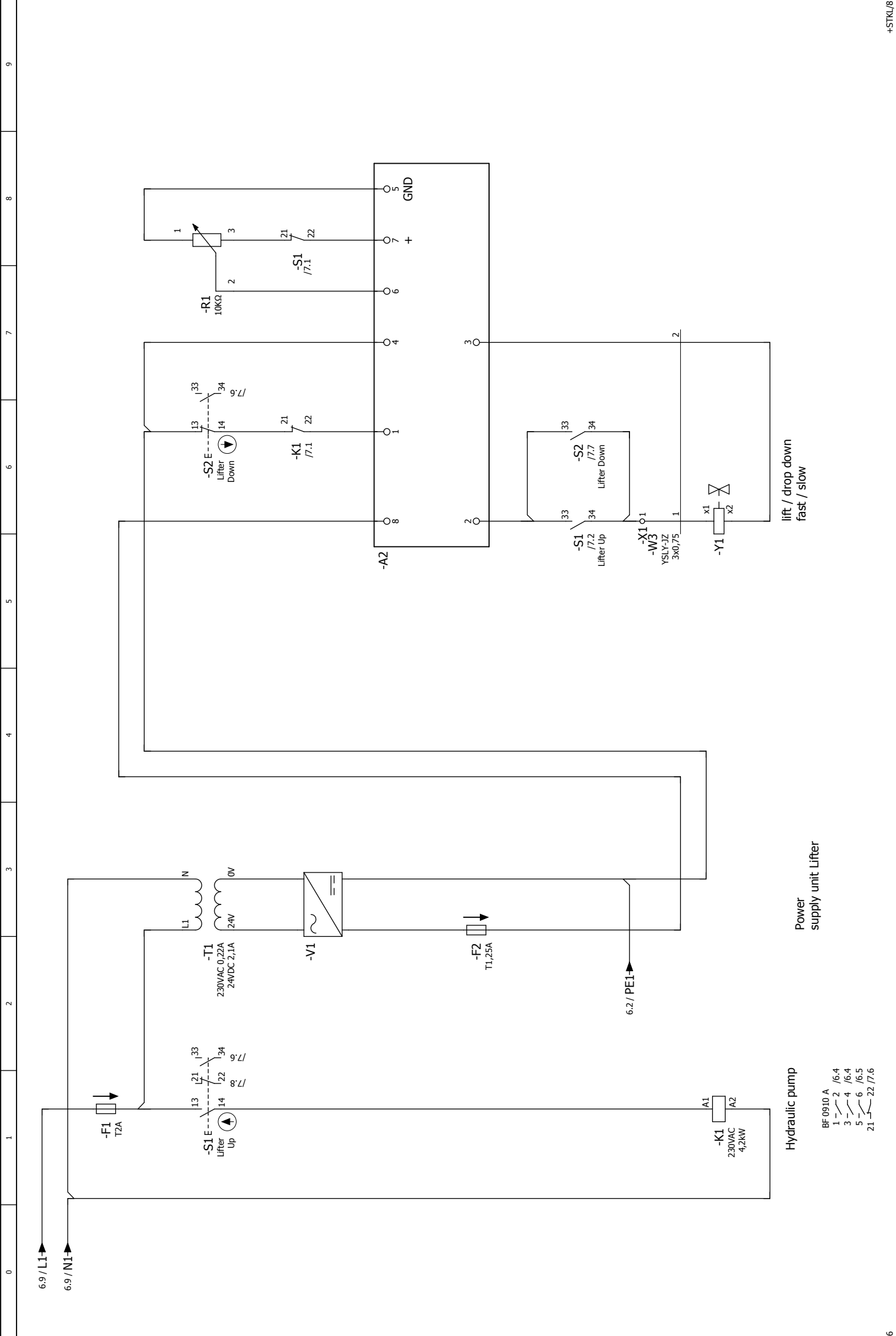

Parts list

MAHA_hsc001

BMK Placement	Quantity ME	designation	Type number Order number	manufacturer supplier	MAHA-Part No.
A2 =Z5+S0/7.5	1		EV1M2-12/24	Hawe Boßert Electronic GmbH	53 9037
F1 =Z5+S0/7.1	1	Fused terminal	M4/8 SF KLEMME-20	Entrelec Boßert Electronic GmbH	53 9026
F1 =Z5+S0/7.1	1	miniature fuse	T 2,0 A	Bürklin OHG	53 3148
F2 =Z5+S0/7.3	1	Fused terminal	M4/8 SF KLEMME-20	Entrelec Boßert Electronic GmbH	53 9026
F2 =Z5+S0/7.3	1	end plate for fuse clip	ABP ABSCHLUSSPLATTE01	Entrelec Boßert Electronic GmbH	53 9030
F2 =Z5+S0/7.3	1	Fuse T 1,25 A			53 3058
K1 =Z5+S0/7.1	1	main contactor 4,2 kW 220-230V 50-60 Hz	BF 0910 A NESÜ.BF9.10	LOVATO electric Boßert Electronic GmbH	53 9004
Q1 =Z5+S0/6.0	1 Stück	main switch 25A 4 pole	NLT25A/4ZM/Z20/F908 50 1002	SONTHEIMER Elektroschaltgeräte GmbH SONTHEIMER Elektroschaltgeräte GmbH	50 1002
S1 =Z5+S0/7.1	1		M22-D-X 51 0500	Moeller GmbH	51 0500
S1 =Z5+S0/7.1	1		M22-XD-S-X7 51 0592	Moeller GmbH	51 0592
S1 =Z5+S0/7.1	1		M22-A 51 0561	Moeller GmbH	51 0561
S1 =Z5+S0/7.1	2 Stück	Contact NO	M22-K10 51 0555	Moeller GmbH	51 0555
S1 =Z5+S0/7.1	1		M22-K01 51 0556	Moeller GmbH	51 0556
S2 =Z5+S0/7.6	1		M22-D-X 51 0500	Moeller GmbH	51 0500
S2 =Z5+S0/7.6	1		M22-XD-S-X7 51 0592	Moeller GmbH	51 0592
S2 =Z5+S0/7.6	1		M22-A 51 0561	Moeller GmbH	51 0561
S2 =Z5+S0/7.6	1	Contact NO	M22-K10 51 0555	Moeller GmbH	51 0555
S2 =Z5+S0/7.6	1		M22-K01 51 0556	Moeller GmbH	51 0556
T1 =Z5+S0/7.3	1	power supply with rectifier	NR.TRNT5 NET.TRNT50	Ulmer Transformatoren GmbH Boßert Electronic GmbH	NET.TRNT50
V1 =Z5+S0/7.3	1	rectifier 3A	universal-LP04 GLEICHRICHTER01	Boßert Electronic GmbH Boßert Electronic GmbH	52 1004
W2 =Z5+S0/6.4	1 m	Cable Adern nummeriert	YSLY-JZ 7 X 1,5 53 1257		53 1257
X0 =Z5+S0/6.0	1 Stück	Ceconstecker 16A	CT 516/6H 53 0078		53 0078

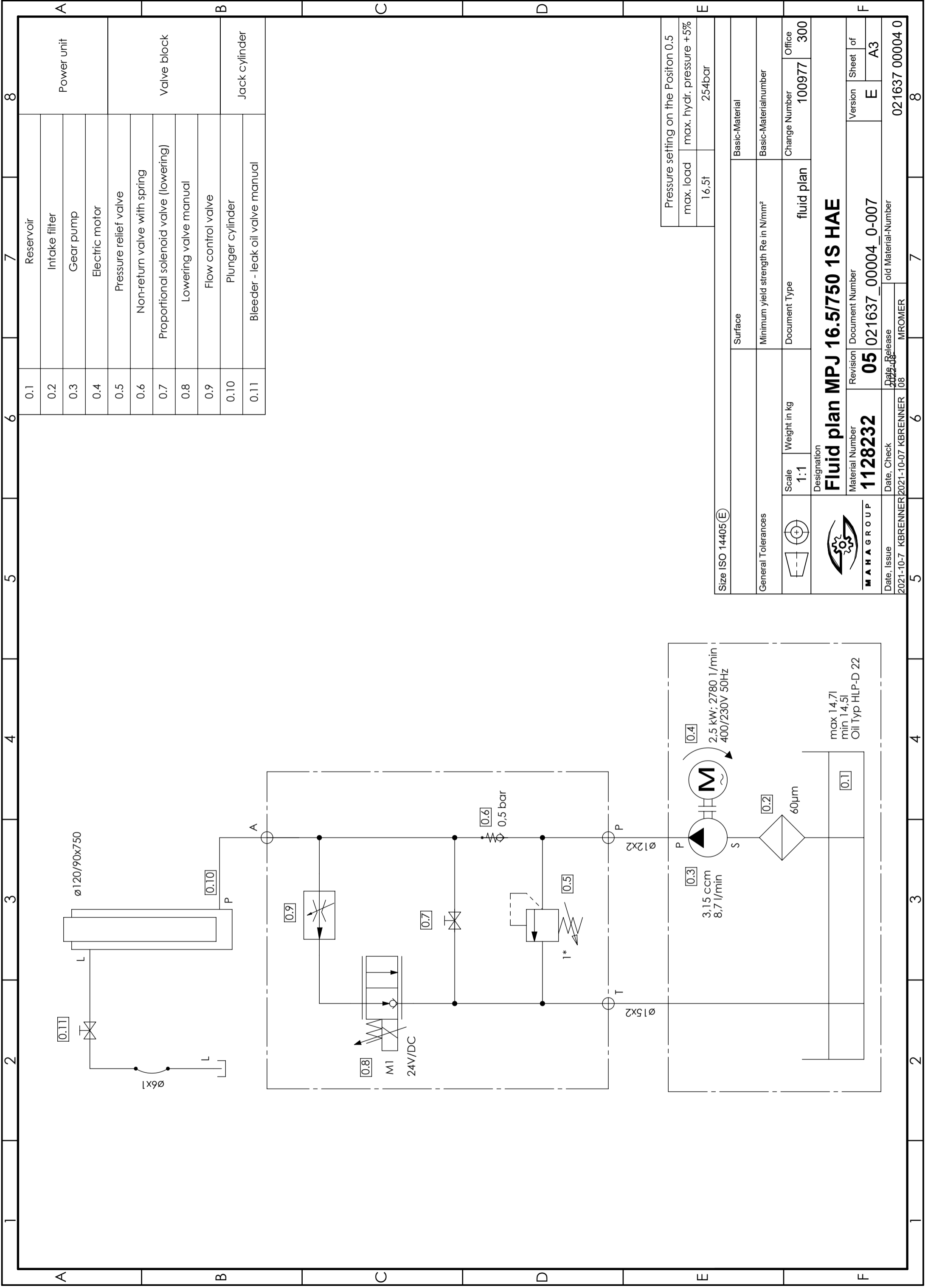

0.1	Reservoir	Power unit
0.2	Intake filter	
0.3	Gear pump	
0.4	Electric motor	Valve block
0.5	Pressure relief valve	
0.6	Non-return valve with spring	
0.7	Proportional solenoid valve (lowering)	Jack cylinder
0.8	Lowering valve manual	
0.9	Flow control valve	
0.10	Plunger cylinder	
0.11	Bleeder - leak oil valve manual	

Pressure setting on the Position 0.5	
max. load	max. hydr. pressure +5%
16,5t	254bar

Size ISO 14405 (E)				
Surface				
Basic-Material				
Minimum yield strength Re in N/mm²				
Basic-Materialnumber				
Scale	Weight in kg	Document Type	Change Number	Office
1:1		fluid plan	100977	300
Designation				
Fluid plan MPJ 16.5/750 1S HAE				
Material Number	Revision	Document Number	Version	Sheet of
1128232	05	021637_00004_0-007	E	A3
Date, Issue	Date, Check	Date, Release	old Material-Number	
2021-10-7	2021-10-07	08	021637 00004 0	
KBRENNER		MFROMER		

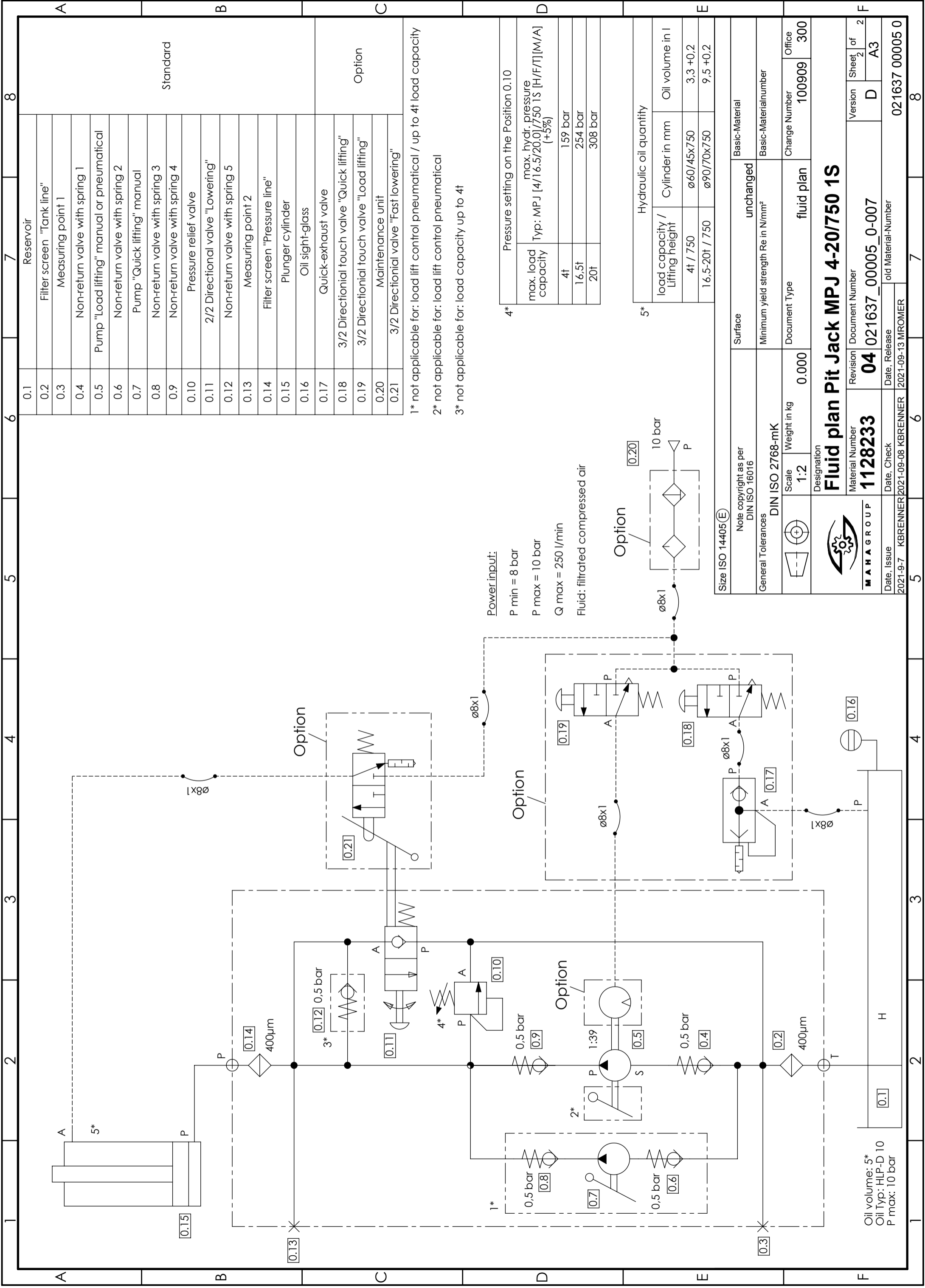

0.1	Reservoir	Standard
0.2	Filter screen "Tank line"	
0.3	Measuring point 1	
0.4	Non-return valve with spring 1	
0.5	Pump "Load lifting" manual or pneumatical	
0.6	Non-return valve with spring 2	
0.7	Pump "Quick lifting" manual	
0.8	Non-return valve with spring 3	
0.9	Non-return valve with spring 4	
0.10	Pressure relief valve	
0.11	2/2 Directional valve "Lowering"	
0.12	Non-return valve with spring 5	
0.13	Measuring point 2	
0.14	Filter screen "Pressure line"	
0.15	Plunger cylinder	
0.16	Oil sight-glass	
0.17	Quick-exhaust valve	
0.18	3/2 Directional touch valve "Quick lifting"	Option
0.19	3/2 Directional touch valve "Load lifting"	
0.20	Maintenance unit	
0.21	3/2 Directional valve "Fast lowering"	

1* not applicable for: load lift control pneumatical / up to 4t load capacity
 2* not applicable for: load lift control pneumatical
 3* not applicable for: load capacity up to 4t

4*	Pressure setting on the Position 0.10
	max. load capacity Typ: MPJ [4/16.5/20.0]/750 1S [H/F/T][M/A] (+5%)
	4t
	16.5t
	20t
5*	Hydraulic oil quantity
	load capacity / Lifting height
	Cylinder in mm
	Oil volume in l
	4t / 750
	ø60/45x750
	3,3 +0,2
	16,5-20t / 750
	ø90/70x750
	9,5 +0,2

Size ISO 14405(E)	Surface	unchanged	Basic-Material
Note copyright as per DIN ISO 16016			
General Tolerances		Minimum yield strength Re in N/mm ²	Basic-Materialnumber
DIN ISO 2768-mK			
Scale	Weight in kg	Document Type	Change Number
1:2	0.000	fluid plan	100909
Designation		Office	300
Fluid plan Pit Jack MPJ 4-20/750 1S			
Material Number	Revision	Document Number	Version
1128233	04	021637_00005_0-007	D
Date, Issue	Date, Check	Date, Release	Sheet 2 of 2
2021-9-7	KBRENNER	2021-09-13	A3
2021-09-08	KBRENNER	2021-09-13	021637 00005 0

Power input:
 P min = 8 bar
 P max = 10 bar
 Q max = 250 l/min
 Fluid: filtrated compressed air

0.1	Oil volume: 5*
	Oil Typ: HLP-D 10
	P max: 10 bar
0.16	0.16
0.17	0.17
0.18	0.18
0.19	0.19
0.20	0.20
0.21	0.21
0.10	0.10
0.09	0.09
0.08	0.08
0.07	0.07
0.06	0.06
0.05	0.05
0.04	0.04
0.03	0.03
0.02	0.02
0.01	0.01

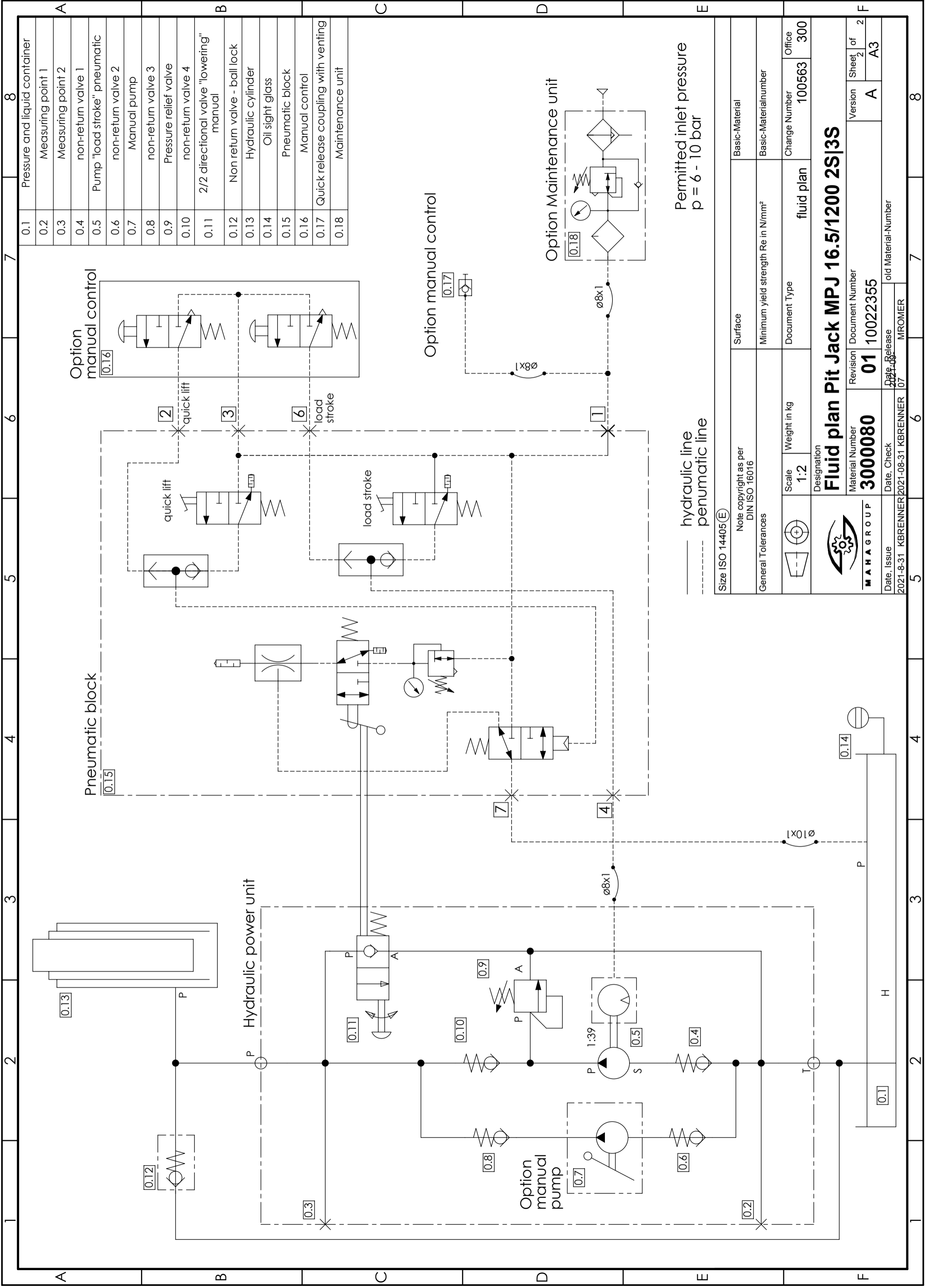

Permitted inlet pressure
 $p = 6 - 10 \text{ bar}$

— hydraulic line
 - - - pneumatic line

Size ISO 14405(E)	Surface	Basic-Material
Note copyright as per DIN ISO 16016	Minimum yield strength R_e in N/mm ²	Basic-Materialnumber
General Tolerances	Document Type	Change Number
	Scale 1:2	Weight in kg
	Weight in kg	Document Type
	Material Number	Revision
MHA GROUP	3000080	01
Date, Issue	Date, Check	Date, Release
2021-8-31	KBRENNER	2021-08-07
	2021-08-31	KBRENNER
		MIFOMER
Designation	Material Number	Revision
Fluid plan Pit Jack MPJ 16.5/1200 2S 3S	3000080	01
Document Number	Document Number	Version
10022355	10022355	A
Sheet 2 of 2	Office	Change Number
A3	300	100563

LFR(S)-/LR(S)-/LF(M.../X)----D

Filter regulator, Pressure regulator, Filter

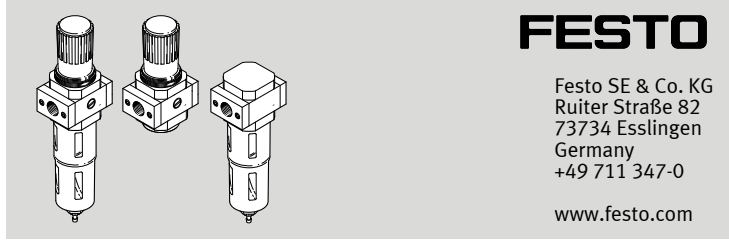

FESTO

Festo SE & Co. KG
Rüter Straße 82
73734 Esslingen
Germany
+49 711 347-0

www.festo.com

Instructions | Operating

8121613
2019-11k
[8121615]



Translation of the original instructions

© 2019 all rights reserved to Festo SE & Co. KG

1 Further applicable documents



All available documents for the product → www.festo.com/pk.

2 Safety

2.1 Safety instructions

- Only use the product in original status without unauthorised modifications.
- Only use the product if it is in perfect technical condition.
- Observe labelling on the product.
- Take into consideration the ambient conditions at the location of use.
- Prior to mounting, installation and maintenance work: Switch off compressed air supply and secure it from being switched back on.
- Observe tightening torques. Unless otherwise specified, the tolerance is $\pm 20\%$.

2.2 Intended Use

Type	Product	Intended Use
LFR(S)----D-MINI/MIDI/MAXI	Filter regulator	<ul style="list-style-type: none"> – Regulates the compressed air in the subsequent string to the set outlet pressure p_2. – Smooths out pressure fluctuations. – Removes dirt particles and condensate from the compressed air.
LR(S)----D-MINI/MIDI/MAXI	Pressure control valve	<ul style="list-style-type: none"> – Regulates the compressed air in the subsequent string to the set outlet pressure p_2. – Smooths out pressure fluctuations.
LF-...-D-MINI/MIDI/MAXI	Filter	Removes dirt particles and condensate from the compressed air.
LFMA-...-D-MINI/MIDI/MAXI	Micro filter (0.01 μm)	Removes dirt particles and oil drops from the compressed air.
LFMB-...-D-MINI/MIDI/MAXI	Fine filter (1 μm)	Removes dirt particles and oil drops from the compressed air.
LFX-...-D-MINI/MIDI/MAXI	Active carbon filter	Removes gaseous oil components from the compressed air.

Tab. 1 Intended Use

2.3 Training of Qualified Personnel

Installation, commissioning, maintenance and disassembly should only be conducted by qualified personnel.

The skilled personnel must be familiar with the installation of pneumatic control systems.

3 Further information

- Accessories → www.festo.com/catalogue.
- Spare parts → www.festo.com/spareparts.

4 Service

Contact your regional Festo contact person if you have technical questions → www.festo.com.

5 Product Design

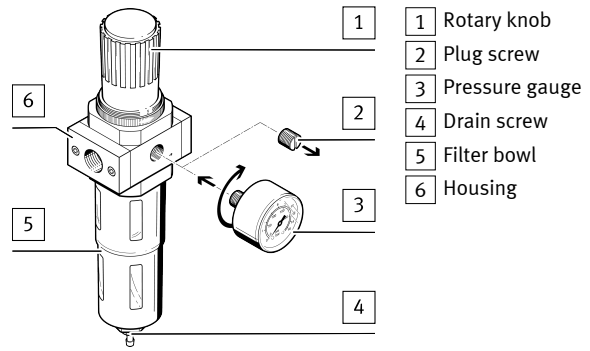

Fig. 1 Product design of filter regulator LFR(S)

6 Mounting

6.1 Mounting Clearances

- Maintain sufficient space around the product.
 - Space required above the product: 80 mm
 - Space required under the product: 90 mm
 - Space required left and right of the product: 90 mm

6.2 Preparation

1. Observe the mounting position → 13 Technical Data.
2. Note the flow direction of flow as shown by the numbers on the housing [6]: from 1 to 2.
3. Mounting accessories: → www.festo.com/catalogue.

6.3 Assembly of a Filter Combination

- Observe the sequence along the flow direction.
 - Fine filter LFMB (1 μm), micro filter LFMA (0.01 μm), active carbon filter LFX.

6.4 Mounting the Pressure Gauge PAGN

1. LFR(S)/LR(S)----O:
 - Remove the plug screw [2] on the pressure gauge connection or on the alternative connection on the back of the device.
 LFR(S)/LR(S) with pressure gauge in scope of delivery:
 - When using an alternative connection on the back of the device: use a plug screw.
2. Turn pressure gauge [3] clockwise to the stop. The pressure gauge seal is pre-assembled on the threaded connection journal. To align the pressure gauge, the pressure gauge can be turned back by a maximum of one rotation.

6.5 Assembly

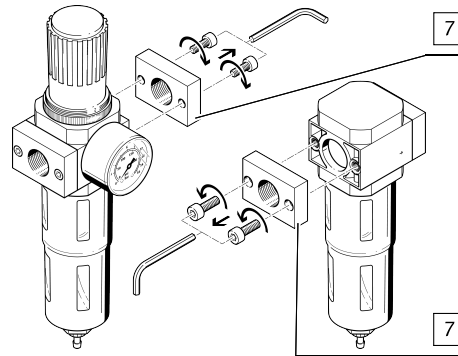

[7] Sub-base

Fig. 2 LFR(S)/LR(S)

1. If available: remove sub-base [7] from both add-on products on the sides to be fitted together.

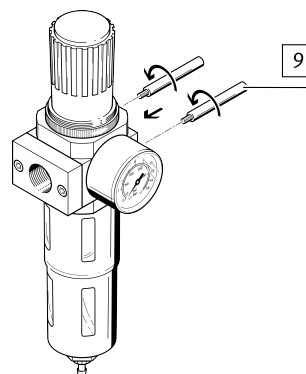

[9] Threaded bolt

Fig. 3 LFR(S)

- Screw in threaded bolt FRB-D [9]. Tightening torque: 2.5 – 0.5 Nm

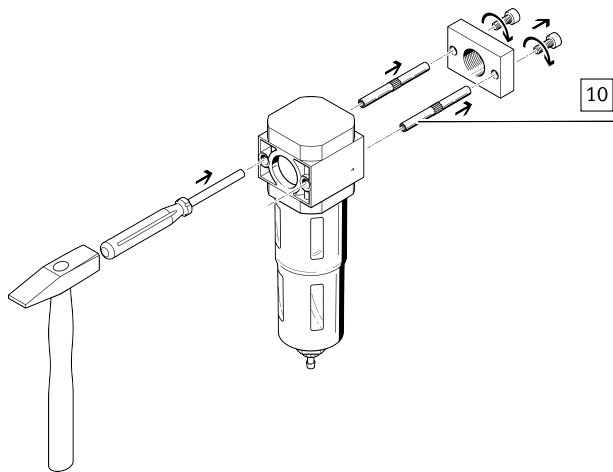

10 Spacer bolts

Fig. 4 LR(S)

- Remove the sub-base on the respective add-on product. Drive out the corresponding spacer bolts [10]. Driving action in flow direction.

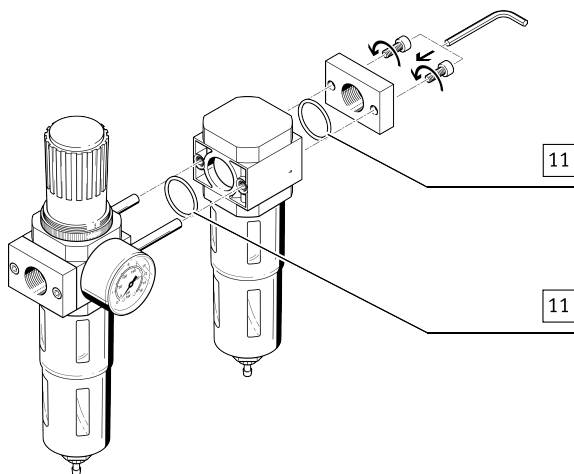

11 Seal

Fig. 5 LFR(S)/LR(S)

- Mount the add-on product with the sub-base. There must be one seal [11] each between the add-on products and the sub-base.

7 Pneumatic Installation

- Fittings, seals, suitable hoses: accessories → www.festo.com/catalogue.
- Screw fittings into the pneumatic ports.
- Push suitable hoses into the fitting up to the stop.
 - Position hoses axial to the pneumatic ports.
 - Do not exceed the minimum bending radius for the hoses.

8 Setting the Outlet Pressure

- Unlock rotary knob [1] (pull).
- Turn the rotary knob completely in the – direction.
- Exhaust system slowly: turn the rotary knob in the + direction until the desired pressure is reached.

Maintain permissible pressure regulation range → 13 Technical Data.
The input pressure p1 should always be at least 1 bar higher than the set outlet pressure p2.
- Lock the rotary knob [1].

9 Maintenance

9.1 Draining the Condensate

Manually Draining the Condensate

If the condensate reaches a level approx. 10 mm below the filter element:

- Turn drain screw [4] anticlockwise as seen from below.
 - The condensate flows out.
- Turn drain screw clockwise as seen from below.

Automatic Draining of the Condensate LFR(S)/LF...-A

The filter drains automatically.

9.2 Changing the Filter

- Unscrew the filter bowl [5].
- Disassemble the old filter cartridge:
 - LFR(S)/LF: unscrew the filter plate and remove the filter cartridge.
 - LFM.../LFX: unscrew the filter cartridge.
- Install new filter cartridge:
 - LFR(S)/LF: place filter cartridge on the filter plate. Screw filter plate in until it stops.
 - LFM.../LFX: hold filter cartridge at the bottom. Screw filter cartridge in until it stops.
- Screw in filter bowl. Tightening torque: MINI: 2 Nm, MIDI/MAXI: 2.5 Nm.

9.3 Cleaning

- Clean the outside of the product as required with a soft cloth.

Permissible cleaning agents:

 - Soap suds (max. +60 °C)
 - Petroleum ether (free of aromatic compounds)

10 Fault Clearance

Error description	Cause	Remedy
Low flow rate (operating pressure breaks down with air consumption)	Constriction in the supply line	Check supply line
	Filter cartridge is dirty	Replace filter cartridge → 9 Maintenance.
Pressure increases above the set working pressure	Valve disc defective at sealing seat	Replace product
Audible, continuous blowing noise at rotary knob	Valve seat damaged	Replace product
Blowing noise can be heard at the drain screw.	Drain screw leaking	Replace product or filter bowl

Tab. 2 Fault Clearance

11 Disassembly

- Exhaust the complete system and product.
- Release interlock at the fittings by pressing it and pull out hose assembly.
- Release fittings at the connecting flanges and unscrew.

12 Disposal

ENVIRONMENT!

Send the packaging and product for environmentally sound recycling in accordance with the current regulations → www.festo.com/sp.

13 Technical Data

Product	LFR(S)	LR(S)	LF	LFM	LFX
Mounting position	[°] Vertical +/-5				
Temperature ranges					
Temperature of medium	[°C] -10 ... +60			1.5 ... 60	5 ... 30
Ambient temperature	[°C] -10 ... +60				
Operating medium					
Compressed air to ISO 8573-1:2010	[-:9:-]			[6:8:4]	[1:4:2]
Input pressure					
Without fully automatic condensate drain	[MPa]	≤ 1.6			
	[bar]	≤ 16			
	[psi]	≤ 232			
With fully automatic condensate drain	[MPa]	0.2 ... 1.2			
	[bar]	2 ... 12			
	[psi]	29 ... 174			
Pressure regulation range					
For LFR(S)/LR(S)-...-D-7	[MPa]	0.05 ... 0.7			
	[bar]	0.5 ... 7			
	[psi]	7 ... 101			
For LFR(S)/LR(S)-...-D	[MPa]	0.05 ... 1.2			
	[bar]	0.5 ... 12			
	[psi]	7 ... 174			

Tab. 3 Technical Data

i

Replace the filter cartridge if the flow rate is reduced even though the pressure setting is unchanged.

- Exhaust compressed air from the product.



**Original-EG-Konformitätserklärung
Original EC Declaration of Conformity**

CE551501-de-en



MAHA Maschinenbau Haldenwang GmbH & Co. KG

erklärt hiermit als Hersteller in alleiniger Verantwortung, dass nachstehend bezeichnetes Produkt in Konzeption und Bauart den grundlegenden Sicherheits- und Gesundheitsanforderungen der hier genannten Richtlinien entspricht.

Bei Änderungen am Produkt, die nicht von oben genannter Firma genehmigt wurden, verliert diese Erklärung ihre Gültigkeit.

herewith declares as a manufacturer its sole responsibility to ensure that the product named hereafter meets the safety and health regulations both in design and construction required by the directives stated below.

This declaration becomes void if any change is made to the product that was not approved by named company beforehand.

Typ | Model

MPJ 16.5/1200 2S FA
MPJ 16.5/1200 2S TA
MPJ 16.5/1200 2S HA
MPJ 16.5/1200 3S FA
MPJ 16.5/1200 3S TA

Seriennummer | Serial Number

Bezeichnung | Designation

Grubenheber
Zulässige Traglast: 16 500 kg

Pit Jack
Rated Load Capacity: 16 500 kg

Richtlinien | Directives

2006/42/EG

2006/42/EC

Normen | Standards

DIN EN 1494

**Bevollmächtigter für die Zusammenstellung der technischen Unterlagen
Person Authorised to Compile the Technical File**

Ralf Kerkmeier
MAHA Maschinenbau Haldenwang GmbH & Co. KG, Hoyen 20, 87490 Haldenwang, Germany

Haldenwang, 2021-03-15

Andreas Maier
CE-Bevollmächtigter | Authorised CE Representative



Original-EG-Konformitätserklärung Original EC Declaration of Conformity

CE551601-de-en



MAHA Maschinenbau Haldenwang GmbH & Co. KG

erklärt hiermit als Hersteller in alleiniger Verantwortung, dass nachstehend bezeichnetes Produkt in Konzeption und Bauart den grundlegenden Sicherheits- und Gesundheitsanforderungen der hier genannten Richtlinien entspricht.

Bei Änderungen am Produkt, die nicht von oben genannter Firma genehmigt wurden, verliert diese Erklärung ihre Gültigkeit.

herewith declares as a manufacturer its sole responsibility to ensure that the product named hereafter meets the safety and health regulations both in design and construction required by the directives stated below.

This declaration becomes void if any change is made to the product that was not approved by named company beforehand.

Typ | Model

MPJ 4.0/750 1S HM
MPJ 4.0/750 1S HA
MPJ 16.5/750 1S HM
MPJ 16.5/750 1S HA
MPJ 16.5/750 1S FA
MPJ 16.5/750 1S TA
MPJ 20.0/750 1S HM
MPJ 20.0/750 1S HA
MPJ 20.0/750 1S FA
MPJ 20.0/750 1S TA

Seriennummer | Serial Number

Bezeichnung | Designation

Grubenheber
Zulässige Traglast: 4000 / 16 500 / 20 000 kg

Pit Jack
Rated Load Capacity: 4000 / 16 500 / 20 000 kg

Richtlinien | Directives

2006/42/EG

2006/42/EC

Normen | Standards

DIN EN 1494

Bevollmächtigter für die Zusammenstellung der technischen Unterlagen Person Authorised to Compile the Technical File

Ralf Kerkmeier
MAHA Maschinenbau Haldenwang GmbH & Co. KG, Hoyen 20, 87490 Haldenwang, Germany

Haldenwang, 2021-11-30

Andreas Maier
CE-Bevollmächtigter | Authorised CE Representative



**Original-EG-Konformitätserklärung
Original EC Declaration of Conformity**

CE551701-de-en



MAHA Maschinenbau Haldenwang GmbH & Co. KG

erklärt hiermit als Hersteller in alleiniger Verantwortung, dass nachstehend bezeichnetes Produkt in Konzeption und Bauart den grundlegenden Sicherheits- und Gesundheitsanforderungen der hier genannten Richtlinien entspricht.

Bei Änderungen am Produkt, die nicht von oben genannter Firma genehmigt wurden, verliert diese Erklärung ihre Gültigkeit.

herewith declares as a manufacturer its sole responsibility to ensure that the product named hereafter meets the safety and health regulations both in design and construction required by the directives stated below.

This declaration becomes void if any change is made to the product that was not approved by named company beforehand.

Typ | Model

MPJ 16.5/750 1S HAE

Seriennummer | Serial Number

Bezeichnung | Designation

Grubenheber
Zulässige Traglast: 16 500 kg

Pit Jack
Rated Load Capacity: 16 500 kg

Richtlinien | Directives

2006/42/EG

2006/42/EC

Normen | Standards

DIN EN 1494

**Bevollmächtigter für die Zusammenstellung der technischen Unterlagen
Person Authorised to Compile the Technical File**

Ralf Kerkmeier
MAHA Maschinenbau Haldenwang GmbH & Co. KG, Hoyen 20, 87490 Haldenwang, Germany

Haldenwang, 2021-11-30

Andreas Maier
CE-Bevollmächtigter | Authorised CE Representative

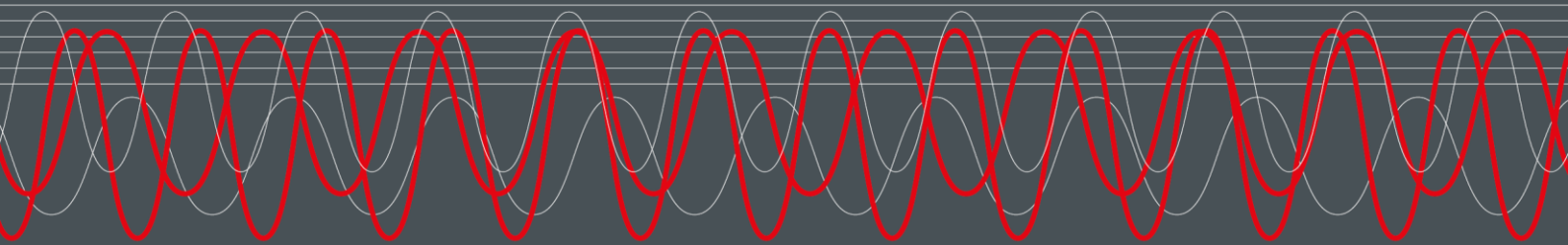

MAHA MASCHINENBAU HALDENWANG GMBH & CO. KG

Hoyen 20
87490 Haldenwang
Germany

☎ +49 8374 585 0
✉ maha@maha.de
🌐 maha.de